

ENR-0135

Features

- universal AC input, 85 ~ 264VAC with 0.98 active PFC
- high output efficiency up to 83% at low line full load
- RoHS compliant
- International regulatory approvals
- Includes steering (Oring) diodes for N+1 hot-swap redundancy. Hot insertion/removal.
- I²C interface, power status LED



Application – Data Storage Server



Order Information

ENR – XX XX



Specifications

MODEL No.	ENR-0135					
	PARAMETER	SYMBOL	MIN	MAX	UNITS	NOTES
INPUT	Line Voltage	Vac	85	264	Vrms	350 Watts
	Frequency	f	47	63	Hz	
	Hold Up Time	Thu	1		Cycle (20ms)	Time between loss of input and loss of reg. at 85Vac full load
	AC under Voltage	Vac input	70	80	VRMS	
	Surge Voltage			4	kV peak	Wave shape specified by EN61000-4-5.
	AC Inrush Current	Iir		40	Apk	1/2 cycle, cold start
	Leakage Current	I _{lkg}		3.5	mA rms	Total measured at 264 Vac per IEC60950, with 4 PS simultaneously connected to the same AC Source
	Efficiency	Eff	83		%	Low line full load
	Isolation Voltage	HIPOT	4242		Vrms	Input/Output for 60 sec.
	Ground Continuity	GC	40		A	< 0.1 ohms
Harmonic Distortion	PF	0.98			Meet EN61000-3-2. @50% load	
OUTPUT	Nominal Voltage	V _o	48	54	V	Nom set to 48.0V @ max
	Output Ripple / Spike Voltage	V _{rip}		480	mV pk-pk	f=0-20MHz, Measured @ back plane with .1uF cap.
	Over Voltage Protection	OVP		60	V	Latching type
	DC OK limits	UVL	40.5	42	V	
	Output Current	I _o	0.5	7.3	A	
	Current Limit	I _{lim}		9.5	A	Latching type (with 130ms of delay)
	Short Circuit Current	I _{sc}		N/a	A	Latching type (with 130ms of delay)
	Transient Recovery Time	T _{tr}		500	mSec	Time req'd for output to settle within 1% of its final value after a 25% load change
	Transient Response Deviation	%V _o		5	%	Over/Under Shoot 25% load change @ 1A/usec
	5V_HSK Current	I_HSK		200	mA	
ENVIRONMENT	Operating Temperature	0 to 50°C @ 10000 ft.				
	Storage Temperature	-40 to 70°C				
	Thermal Shock	Non operating -40(+/-5)°C to 70(+/-5)°C, transition time not to exceed 5 minutes. Duration of exposure to temperature extremes will be 20 minutes				
	Humidity	5-95% Non-condensing				
	Airflow	The cooling of power supply is internal and have two fans. In case of one of the two fans stops working power supply should perform without thermal shut down. Fan fail signal to be reported to I2C and also fault LED will turn on which indicates the problem.				
	ROHS	Directive 2002/95/EC				
MTBF	Acoustic	A single power supply with both fans operating should not to exceed 40dBA				
	DMTBF	Demonstrated MTBF of 2,000,000 hours				
	MTBF	Calculated MTBF of 150,000 hours				
SAFETY/EMC	UL/cUL, CSA, TUV, NEMKO, CE, CCC (China), BSMI(Taiwan)/CE, FCC					

1U-Redundant

1U-Redundant

Mechanical Drawing

Unit: mm

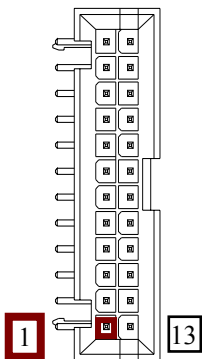
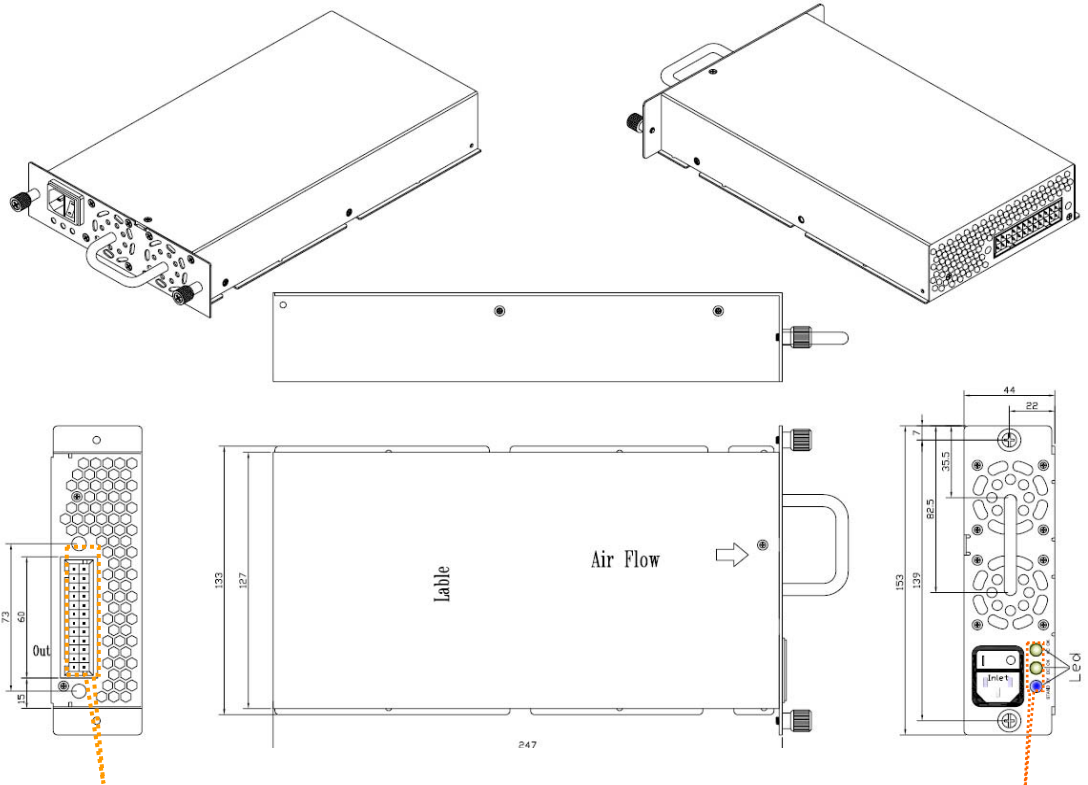

Signal	Pin #	Definition
48V	1,13,14	48V Power Rail
48V RTN	2,3,15	48V Power Return
DC-OK	7	Output Power OK
AC-OK	6	Input Power OK
Enable-N	23	Output Power Enable
Remote ON/OFF	24	Output Power On/OFF
PS-IN	21	PS-PRESENT
+5V-HSK	22	5V Output
OVP	20	Over Voltage Test
Logic GND	17	Logic GND
SCL	8	Serial Clock
SDA	9	Serial Data
A0	12	Address-A0
A1	11	Address-A1
A2	10	Address-A2
	4,5,16,18,19	Not USED

Notes

- Specification subject to change without notice.
- All company logo and legal name belong to original company. All copyright reserved by Enhance Electronics.
- One-Year Standard Warranty
- Last Update: 6/23/2009