

# SFX/SFX12V Power Supply Design Guide

**Version 2.2**

---

## Document Revision

Version	Release Date	Notes
1.0	12/97	Public release
1.1	4/98	<ul style="list-style-type: none"><li>• Updated all mechanical outlines to clean up dimensioning of mounting holes.</li><li>• Added chassis cutouts for all mechanical outlines to clarify keep-out areas.</li><li>• Added Appendix C.</li></ul>
2.0	5/01	<ul style="list-style-type: none"><li>• Added SFX12V description</li><li>• Additional power ratings added</li><li>• Updated industry standards</li><li>• Increased standby current</li></ul>
2.1	8/01	<ul style="list-style-type: none"><li>• Section 4.4 Updated Figure 4 SFX/SFX12V Connectors</li><li>• Section 5.8 removed vendor name</li></ul>
2.2	12/05	<ul style="list-style-type: none"><li>• Section 3.23 Typical Power Distribution. Change minimum loading on 5V rail to 0.3A</li><li>• Section 3.3.2 PS_ON#. Add text "The power supply should not latch into a shutdown state when PS_ON# is driven active by pulses between 10ms to 100ms during the decay of the power rails."</li></ul>

## **IMPORTANT INFORMATION AND DISCLAIMERS**

1. INTEL CORPORATION (AND ANY CONTRIBUTOR) IS PROVIDING THIS INFORMATION AS A CONVENIENCE AND ACCORDINGLY MAKES NO WARRANTIES WITH REGARD TO THIS DOCUMENT. IN PARTICULAR, INTEL (AND ANY CONTRIBUTOR) DOES NOT WARRANT OR REPRESENT THAT THIS DOCUMENT OR ANY PRODUCTS MADE IN CONFORMANCE WITH IT WILL OPERATE IN THE INTENDED MANNER. NOR DOES INTEL (OR ANY CONTRIBUTOR) ASSUME RESPONSIBILITY FOR ANY ERRORS THAT THE DOCUMENT MAY CONTAIN.
2. NO REPRESENTATIONS OR WARRANTIES ARE MADE THAT ANY PRODUCT BASED IN WHOLE OR IN PART ON THE ABOVE DOCUMENT WILL BE FREE FROM DEFECTS OR SAFE FOR USE FOR ITS INTENDED PURPOSE. ANY PERSON MAKING, USING OR SELLING SUCH PRODUCT DOES SO AT HIS OR HER OWN RISK.
3. INTEL DISCLAIMS ALL LIABILITY ARISING FROM USE OF OR IN CONNECTION WITH THE INFORMATION PROVIDED IN THIS DOCUMENT, INCLUDING LIABILITY FOR INFRINGEMENT OF ANY PROPRIETARY RIGHTS RELATING TO THE INFORMATION OR THE IMPLEMENTATION OF INFORMATION IN THIS DOCUMENT. INTEL DOES NOT WARRANT OR REPRESENT THAT SUCH DEVICES OR IMPLEMENTATION WILL NOT INFRINGE SUCH RIGHTS. INTEL IS NOT OBLIGATED TO PROVIDE ANY SUPPORT, INSTALLATION OR OTHER ASSISTANCE WITH REGARD TO THE INFORMATION.
4. THE INFORMATION REFERRED TO IN THIS DOCUMENT IS INTENDED FOR STANDARD COMMERCIAL USE ONLY. CUSTOMERS ARE SOLELY RESPONSIBLE FOR ASSESSING THE SUITABILITY OF THE INFORMATION FOR USE IN PARTICULAR APPLICATIONS. THE INFORMATION IS NOT INTENDED FOR USE IN CRITICAL CONTROL OR SAFETY SYSTEMS, MEDICAL OR LIFE SAVING APPLICATIONS, OR IN NUCLEAR FACILITY APPLICATIONS.
5. NO LICENSE, EXPRESS OR IMPLIED, BY ESTOPPEL OR OTHERWISE, TO ANY INTELLECTUAL PROPERTY RIGHTS IS GRANTED HEREIN.

Copyright © 2000, 2001 Intel Corporation. All rights reserved.

Version 0.9 of updated SFX PSDG, Mar 2001

† Third-party brands and names are the property of their respective owners.

# Contents

---

<b>1. Introduction</b> .....	<b>6</b>
1.1. Scope .....	6
1.2. Proposed changes for Version 2.0.....	6
1.2.1. Reformat.....	6
1.2.2. Increased Power.....	6
1.2.3. Increased +5 VSB Current .....	6
1.2.4. External Fan Control - Optional.....	6
1.2.5. SFX12V .....	7
<b>2. Applicable Documents</b> .....	<b>7</b>
<b>3. Electrical</b> .....	<b>9</b>
3.1. AC Input .....	9
3.1.1. Input Overcurrent Protection .....	9
3.1.2. Inrush Current Limiting .....	9
3.1.3. Input Under Voltage.....	10
3.1.4. Regulatory .....	10
3.1.5. Catastrophic Failure Protection .....	10
3.2. DC Output .....	10
3.2.1. DC Voltage Regulation .....	10
3.2.2. Remote Sensing.....	11
3.2.3. Typical Power Distribution .....	11
3.2.4. Power Limit / Hazardous Energy Levels.....	13
3.2.5. Efficiency .....	13
3.2.6. Output Ripple/Noise .....	14
3.2.7. Output Transient Response .....	15
3.2.8. Capacitive Load.....	16
3.2.9. Closed-loop Stability .....	16
3.2.10. +5 VDC / +3.3 VDC Power Sequencing .....	16
3.2.11. Voltage Hold-up Time.....	16
3.3. Timing / Housekeeping / Control.....	17
3.3.1. PWR_OK.....	17
3.3.2. PS_ON# .....	18
3.3.3. +5 VSB .....	19
3.3.4. Power-on Time .....	19
3.3.5. Rise Time .....	19
3.3.6. Overshoot at Turn-on / Turn-off .....	20
3.3.7. Reset after Shutdown .....	20
3.3.8. +5 VSB at AC Power-down .....	20
3.4. Output Protection .....	20
3.4.1. Over Voltage Protection .....	20
3.4.2. Short-circuit Protection .....	20

3.4.3.	No-load Operation .....	21
3.4.4.	Over Current Protection.....	21
3.4.5.	Over-Temperature Protection.....	21
3.4.6.	Output Bypass .....	21
<b>4.</b>	<b>Mechanical .....</b>	<b>21</b>
4.1.	Labeling / Marking .....	21
4.2.	Airflow / Fan .....	22
4.3.	AC Connector.....	22
4.4.	DC Connectors.....	23
4.4.1.	SFX Main Power Connector .....	24
4.4.2.	Peripheral Connector(s) .....	25
4.4.3.	Floppy Drive Connector .....	25
4.4.4.	+12 V Power Connector (for SFX12V only).....	25
<b>5.</b>	<b>Environmental.....</b>	<b>26</b>
5.1.	Temperature.....	26
5.2.	Thermal Shock (Shipping).....	26
5.3.	Humidity .....	26
5.4.	Altitude .....	26
5.5.	Mechanical Shock .....	26
5.6.	Random Vibration.....	27
5.7.	Acoustics.....	27
5.8.	Ecological Requirements.....	27
<b>6.</b>	<b>Electromagnetic Compatibility .....</b>	<b>28</b>
6.1.	Emissions .....	28
6.1.2	Immunity.....	28
6.2.	Input Line Current Harmonic Content .....	28
6.3.	Magnetic Leakage Fields .....	29
6.4.	Reliability .....	29
6.5.	Mean Time Between Failures (MTBF) .....	29
6.6.	Voltage Fluctuations and Flicker .....	30
<b>7.</b>	<b>Safety .....</b>	<b>30</b>
7.1.	North America .....	30
7.2.	International.....	31
<b>8....</b>	<b>SYSTEM COOLING CONSIDERATIONS.....</b>	<b>31</b>
APPENDIX A	GUIDELINES FOR A LOWER PROFILE PACKAGE .....	32
APPENDIX B	GUIDELINES FOR A TOP MOUNT FAN PACKAGE .....	34
APPENDIX C	GUIDELINES FOR A REDUCED DEPTH, TOP MOUNT FAN PACKAGE .....	37
APPENDIX D	GUIDELINES FOR A LOWER PROFILE PACKAGE .....	40

## Figures

Figure 1. Differential Noise Test Setup.....	15
Figure 2. Power Supply Timing.....	17
Figure 3. PS_ON# Signal Characteristics.....	19
Figure 4. SFX/SFX12V Connectors.....	23
Figure 5 40 mm Profile Mechanical Outline.....	33
Figure 6 Chassis Cutout .....	33
Figure 7 Top Mount Fan Profile Mechanical Outline .....	35
Figure 8 Chassis Cutout .....	36
Figure 9 Recessed Fan Mounting.....	36
Figure 10 Reduced Depth Top Mount Fan Profile Mechanical Outline .....	38
Figure 11 Chassis cutout.....	39
Figure 12 60 mm Mechanical Outline .....	41
Figure 13 Chassis Cutout .....	42

## Tables

Table 1. AC Input Line Requirements.....	9
Table 2. DC Output Voltage Regulation .....	10
Table 3. Typical Power Distribution for a 90 W SFX Configuration .....	11
Table 4. Typical Power Distribution for a 120 W SFX Configuration .....	11
Table 5. Typical Power Distribution for a 150 W SFX Configuration .....	12
Table 6. Typical Power Distribution for a 160 W SFX12V Configuration.....	12
Table 7. Typical Power Distribution for 180 W SFX12V Configuration.....	13
Table 8 Energy Star Input Power Consumption .....	14
Table 9. DC Output Noise/Ripple .....	14
Table 10. DC Output Transient Step Sizes.....	15
Table 11. Output Capacitive Loads .....	16
Table 12. PWR_OK Signal Characteristics .....	18
Table 13. PS_ON# Signal Characteristics.....	18
Table 14. Over Voltage Protection.....	20
Table 15: Harmonic Limits, Class A equipment.....	29

# 1. Introduction

---

## 1.1. Scope

This document provides design suggestions for a family of small form factor power supplies that are primarily intended for use with microATX and FlexATX systems. The connectors conform to the basic requirements of the ATX main board specification except that -5 V is not available. It should not be inferred that all SFX power supplies must conform exactly to the content of this document. The design specifics described are not intended to support all possible systems, because power supply needs vary depending on system configuration.

## 1.2. Proposed changes for Version 2.0

This section provides a brief summary of the proposed changes to revise the SFX Power Supply Design Guide from Version 1.1 to Version 2.0.

### 1.2.1. Reformat

This design guide has been reformatted to more clearly show the case outline options.

### 1.2.2. Increased Power

The trend for faster and more powerful systems results in an increasing need for higher rated power supplies. Additional power ratings have been added with increased 5 VDC and 12 VDC current to meet the needs of present and future system needs. Power ratings have been added at 120 W and 150 W. These have been added for guidance and are not intended to limit the choice of power ratings available.

### 1.2.3. Increased +5 VSB Current

Trends in PC system power management solutions (for example, Instantly Available PC and Suspend-to-RAM) are driving a need for increased +5 VSB current capability for all SFX-family power supplies. The previous +5 VSB output requirement is being raised to 1.0 amps minimum, with 2.0 amps preferred. Recommendations for momentary peak current have also been added to enable USB "wake on" devices. See Section 3.3.3 for details.

### 1.2.4. External Fan Control - Optional

With the implementation of Suspend To RAM (STR or S3 sleep state), the system can obtain a low power condition without the need for external fan shutoff. In STR mode, the main outputs including 12 V are not available from the power supply and all system fans and the power supply fan will be off. FANC and FANM functions described in Version 1.1 have been removed for Version 2.0. Some vendors may still offer the external Fan functions as an option.

## 1.2.5. SFX12V

The latest generation of motherboards will have power delivery based on a 12 V rail. To meet the needs of the higher 12 V current, a new connector has been defined to meet the increased current needs of these motherboards. Wattages at 160 W and 180 W have been defined to meet the requirements of Intel Pentium® 4 processor-based systems.

## 2. Applicable Documents

The latest revision in effect of the following documents forms a part of this document to the extent specified.

Document title	Description
AB13-94-146	European Association of Consumer Electronics Manufacturers (EACEM) Hazardous Substance List / Certification
ANSI C62.41-1991	IEEE Recommended Practice on Surge Voltages in Low-Voltage AC Circuits
ANSI C62.45-1992	IEEE Guide on Surge Testing for Equipment Connected to Low-Voltage AC Power Circuits
MIL-STD-105K	Quality Control
MIL-STD-217F	Reliability Predictions for Electronic Equipment
MIL-C-5541	Chemical Conversion Coatings on Aluminum and Aluminum Alloys
CSA C22.2 No.234, Level 3	Safety of Component Power Supplies (Intended for use with Electronic Data Processing Equipment and Office Machines)
CAN/CSA C22.2 No.950-95, 3 <sup>rd</sup> edition	Safety of Information Technology Equipment Including Electrical Business Equipment
UL 1950, 3 <sup>rd</sup> edition, without D3 Deviation	Safety of Information Technology Equipment Including Electrical Business Equipment
IEC 60950, 2 <sup>nd</sup> ed. 1991: plus A1, A2, A3, A4	Safety of Information Technology Equipment Including Business Equipment
EN 60950, 2 <sup>nd</sup> ed. 1992: plus A1, A2, A3, A4	Safety of Information Technology Equipment Including Business Equipment
EMKO-TSE (74-SEC) 207/94	Nordic national requirement in addition to EN 60950
CISPR 22:1997 3 <sup>rd</sup> edition EN 55022:1998	Limits and Methods of Measurements of Radio Interference Characteristics of Information Technology Equipment, Class B
ANSI C63.4 – 1992	American National Standard for Methods of Measurement of Radio-Noise Emissions from Low-Voltage Electrical and Electronic Equipment in the Range of 9 kHz to 40 GHz for EMI testing
AS/NZS 3548 (Class B)	Australian Communications Authority, Standard for Electromagnetic Compatibility (AU & NZ)
CNS 13438	Limits and methods of measurement of radio disturbance characteristics of Information Technology Equipment (Taiwan & China)
EN 55024:1998	Information technology equipment—Immunity characteristics—Limits and methods of measurement

CISPR 24: 1997	Information technology equipment—Immunity characteristics—Limits and methods of measurement
EN 61000-3-2	Electromagnetic compatibility (EMC)—Part 3: Limits—Section 2: Limits for harmonic current emissions, Class D
IEC 61000-4-	Electromagnetic compatibility (EMC) for industrial-process measurement and control equipment—Part 4: Testing and measurement techniques Section -2: Electrostatic discharge Section -3: Radiated, radio-frequency, electromagnetic field Section -4: Electrical fast transient / burst Section -5: Surge Section -6: Conducted disturbances, induced by radio-frequency fields Section -8: Power frequency magnetic fields Section -11: Voltage dips, short interruptions, and voltage variations
Japan Electric Association	Guidelines for the Suppression of Harmonics in Appliances and General Use Equipment
IEC Publication 417	International Graphic Symbol Standard
ISO Standard 7000	Graphic Symbols for Use on Equipment
CFR 47, Part 15, Subpart B	FCC Regulations pertaining to unintentional radiators (USA)
ICES-003 (Class B)	Interference-Causing Equipment Standard, Digital Apparatus (Canada)
VCCI V-3/99.05 (Class B)	Implementation Regulations for Voluntary Control of Radio Interference by Data processing Equipment and Electronic Office Machines (Japan)

## 3. Electrical

---

The electrical requirements that follow are to be met over the environmental ranges specified in Section 5 unless otherwise noted.

### 3.1. AC Input

Table 1 lists AC input voltage and frequency requirements for continuous operation. The power supply shall be capable of supplying full-rated output power over two input voltage ranges rated 100-127 VAC and 200-240 VAC rms nominal. The correct input range for use in a given environment may be either switch-selectable or auto-ranging. The power supply shall automatically recover from AC power loss. The power supply must be able to start up under peak loading at 90 VAC.

**Table 1. AC Input Line Requirements**

Parameter	Minimum	Nominal (Note)	Maximum	Unit
V <sub>in</sub> (115 VAC)	90	115	135	VAC <sub>rms</sub>
V <sub>in</sub> (230 VAC)	180	230	265	VAC <sub>rms</sub>
V <sub>in</sub> Frequency	47	--	63	Hz

Note: Nominal voltages for test purposes are considered to be within  $\pm 1.0$  V of nominal.

#### 3.1.1. Input Overcurrent Protection

The power supply shall incorporate primary fusing for input overcurrent protection to prevent damage to the power supply and meet product safety requirements. Fuses should be slow-blow-type or equivalent to prevent nuisance trips<sup>1</sup>.

#### 3.1.2. Inrush Current Limiting

Maximum inrush current from power-on (with power on at any point on the AC sine) and including, but not limited to, three line cycles, shall be limited to a level below the surge rating of the input line cord, AC switch if present, bridge rectifier, fuse, and EMI filter components. Repetitive ON/OFF cycling of the AC input voltage should not damage the power supply or cause the input fuse to blow.

---

<sup>1</sup> . For Denmark and Switzerland international safety requirements, if the internal over-current protective devices exceed 8A for Denmark and 10A for Switzerland, then the power supply must pass international safety testing to EN 60950 using a maximum 16A over-current protected branch circuit, and this 16A (time delay fuse) branch circuit protector must not open during power supply abnormal operation (output short circuit and component fault) testing.

### 3.1.3. Input Under Voltage

The power supply shall contain protection circuitry such that the application of an input voltage below the minimum specified in Section 3.1, Table 1, shall not cause damage to the power supply.

### 3.1.4. Regulatory

At a minimum, both system and power supply typically must pass safety and EMC testing per the limits and methods described in EN 55024 prior to sale in most parts of the world. Additional national requirements may apply depending on the design, product end use, target geography, customer, and other variables. Consult your company's Product Safety and Regulations department for more details.

### 3.1.5. Catastrophic Failure Protection

Should a component failure occur, the power supply should not exhibit any of the following:

- Flame
- Excessive smoke
- Charred PCB
- Fused PCB conductor
- Startling noise
- Emission of molten material
- Earth ground fault (short circuit to ground or chassis enclosure)

## 3.2. DC Output

### 3.2.1. DC Voltage Regulation

The DC output voltages shall remain within the regulation ranges shown in Table 2 when measured at the load end of the output connectors under all line, load, and environmental conditions. The voltage regulation limits shall be maintained under continuous operation for a period of time equal to or greater than the MTBF specified in Section 6.5 at any steady state temperature and operating conditions specified in Section 5.

**Table 2. DC Output Voltage Regulation**

Output	Range	Minimum	Nominal	Maximum	Unit
+12 VDC (Note)	±5%	+11.40	+12.00	+12.60	Volts
+5 VDC	±5%	+4.75	+5.00	+5.25	Volts
+3.3 VDC	±5%	+3.14	+3.30	+3.47	Volts
-12 VDC	±10%	-10.80	-12.00	-13.20	Volts
+5 VSB	±5%	+4.75	+5.00	+5.25	Volts

Note: At +12 VDC peak loading, regulation at the +12 VDC output can go to ± 10%.

### 3.2.2. Remote Sensing

The +3.3 VDC output should have provisions for remote sensing to compensate for excessive cable drops. The default sense should be connected to pin 11 of the main power connector. The power supply should draw no more than 10 mA through the remote sense line to keep DC offset voltages to a minimum.

### 3.2.3. Typical Power Distribution

DC output power requirements and distributions will vary based on specific system options and implementation. Significant dependencies include the quantity and types of processors, memory, add-in card slots, and peripheral bays, as well as support for advanced graphics or other features. Tables 3 through 7 show the power distribution for power supplies in the range of 90 W to 180 W. It is ultimately the responsibility of the designer to define a power budget for a given target product and market.

## SFX Power Distribution Tables

**Table 3. Typical Power Distribution for a 90 W SFX Configuration**

Output	Minimum Current (amps)	Maximum Current (amps)	Peak Current (amps)
+12 VDC	0.0	1.5	4.8
+5 VDC	0.3	11.0	
+3.3 VDC	0.3	6.0	
-12 VDC	0.0	0.2	
+5 VSB	0.0	1.0	1.5

**Table 4. Typical Power Distribution for a 120 W SFX Configuration**

Output	Minimum Current (amps)	Maximum Current (amps)	Peak Current (amps)
+12 VDC	0.2	3	6
+5 VDC	0.3	12.0	
+3.3 VDC	0.3	6.0	
-12 VDC	0.0	0.2	
+5 VSB	0.0	1.0	2.0

**Table 5. Typical Power Distribution for a 150 W SFX Configuration**

Output	Minimum Current (amps)	Maximum Current (amps)	Peak Current (amps)
+12 VDC	0.2	5	8
+5 VDC	0.3	14.0	
+3.3 VDC	0.3	12.0	
-12 VDC	0.0	0.3	
+5 VSB	0.0	1.5	2.0

### SFX12V Power Distribution Tables

**Table 6. Typical Power Distribution for a 160 W SFX12V Configuration**

Output	Minimum Current (amps)	Maximum Current (amps)	Peak Current (amps)
+12 VDC	2.0	8.0	10.0
+5 VDC	0.3	12.0 (Note)	
+3.3 VDC	0.5	16.7 (Note)	
-12 VDC	0.0	0.3	
+5 VSB	0.0	1.5	2.0

Note: Total combined output of 3.3 V and 5 V is < 61 W.

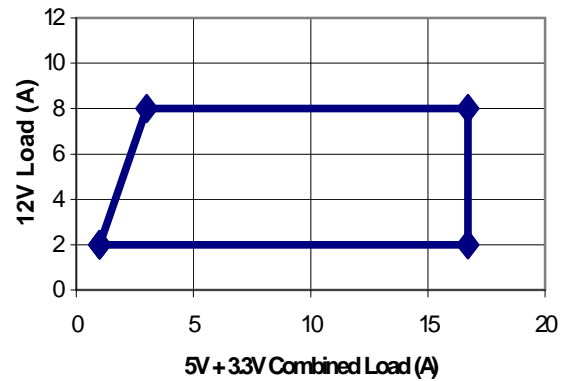

**Table 7. Typical Power Distribution for 180 W SFX12V Configuration**

Output	Minimum Current (amps)	Maximum Current (amps)	Peak Current (amps)
+12 VDC	2.0	10.0	13.0
+5 VDC	0.3	12.0 (Note)	
+3.3 VDC	0.5	16.7 (Note)	
-12 VDC	0.0	0.3	
+5 VSB	0.0	1.5	2.0

Note: Total combined output of 3.3 V and 5 V is < 61 W

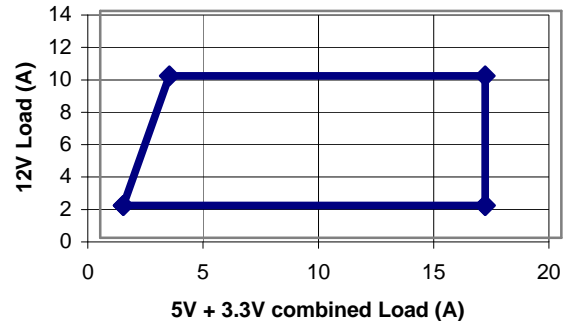

### 3.2.4. Power Limit / Hazardous Energy Levels

Under normal or overload conditions, no output shall continuously provide 240 VA under any conditions of load including output short circuit, per the requirement of UL 1950/CSA 950 / EN 60950/IEC 950.

### 3.2.5. Efficiency

#### 3.2.5.1. General

The power supply should be a minimum of 68% efficient under maximum rated load. The efficiency of the power supply should be met over the AC input range defined in Table 1, under the load conditions defined in Section 3.2.3, and under the temperature and operating conditions defined in Section 7.

#### 3.2.5.2. Energy Star

The “Energy Star” efficiency requirements of the power supply depend on the intended system configuration. In the low-power / sleep state (S1 or S3) the system should consume power in accordance with the values listed in Table 8.

**Table 8 Energy Star Input Power Consumption**

Maximum Continuous Power Rating of Power Supply	RMS Watts from the AC line in sleep/low-power mode
$\leq 200 \text{ W}$	$\leq 15 \text{ W}$
$> 200 \text{ W} \leq 300 \text{ W}$	$\leq 20 \text{ W}$
$> 300 \text{ W} \leq 350 \text{ W}$	$\leq 25 \text{ W}$
$> 350 \text{ W} \leq 400 \text{ W}$	$\leq 30 \text{ W}$
$> 400 \text{ W}$	10% of the maximum continuous output rating

**Note:** To help meet the “Energy Star” system requirements, it is recommended that the power supply have > 50% efficiency at light load and in standby mode.

### 3.2.5.3. Blue Angel, RAL-UZ 78

To help meet the Blue Angel system requirements, the +5 VSB standby supply efficiency should be as high as possible. Standby efficiency is measured with the main outputs off (PS\_ON# high state). To meet Blue Angel system requirements, the AC input power shall not exceed 5 W when the main outputs are in the “DC disabled” state with 500 mA load on +5 VSB and a 230 VAC / 50 Hz input.

### 3.2.6. Output Ripple/Noise

The output ripple/noise requirements listed in Table 9 should be met throughout the load ranges specified in Section 3.2.3 and under all input voltage conditions as specified in Section 3.1.

Ripple and noise are defined as periodic or random signals over a frequency band of 10 Hz to 20 MHz. Measurements shall be made with an oscilloscope with 20 MHz bandwidth. Outputs should be bypassed at the connector with a 0.1  $\mu\text{F}$  ceramic disk capacitor and a 10  $\mu\text{F}$  electrolytic capacitor to simulate system loading. See Figure 1.

**Table 9. DC Output Noise/Ripple**

Output	Maximum Ripple and Noise ( $\text{mV}_{\text{pp}}$ )
+12 VDC	120
+5 VDC	50
+3.3 VDC	50
-12 VDC	120
+5 VSB	50

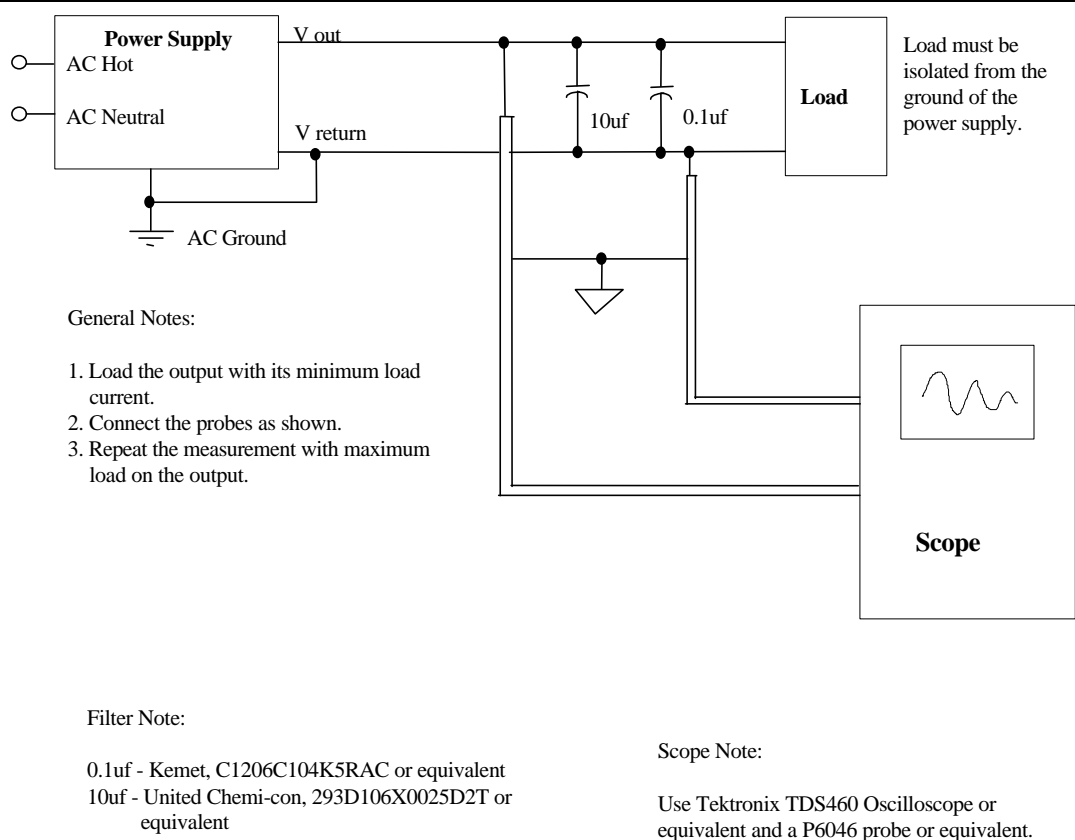

**Figure 1. Differential Noise Test Setup**

### 3.2.7. Output Transient Response

Table 10 summarizes the expected output transient step sizes for each output. The transient load slew rate is = 1.0 A/μs.

**Table 10. DC Output Transient Step Sizes**

Output	Maximum step size (% of rated output amps per Sec 3.2.3) (Note)	Maximum. step size (amps)
+12 VDC	50%	
+5 VDC	30%	
+3.3 VDC	30%	
-12 VDC		0.1 A
+5 VSB		0.5 A

Note: For example, for a rated +5 VDC output of 14 A, the transient step would be 30% × 14 A = 4.2 A

Output voltages should remain within the regulation limits of Table 2, Section 3.2.1 for instantaneous changes in load as specified in Table 10 and for the following conditions:

- Simultaneous load steps on the +12 VDC, +5 VDC, and +3.3 VDC outputs (all steps occurring in the same direction)
- Load-changing repetition rate of 50 Hz to 10 kHz
- AC input range per Section 3.1
- Capacitive loading per Table 11

### 3.2.8. Capacitive Load

The power supply should be able to power up and operate with the regulation limits defined in Table 2, Section 3.2.1 with the following capacitances simultaneously present on the DC outputs.

**Table 11. Output Capacitive Loads**

Output	Capacitive load (mF)
+12 VDC	5,000
+5 VDC	10,000
+3.3 VDC	6,000
-12 VDC	350
+5 VSB	350

### 3.2.9. Closed-loop Stability

The power supply shall be unconditionally stable under all line/load/transient load conditions including capacitive loads specified in Section 3.2.8. A minimum of 45 degrees phase margin and 10 dB gain margin is recommended at both the maximum and minimum loads.

### 3.2.10. +5 VDC / +3.3 VDC Power Sequencing

The +12 VDC and +5 VDC output levels must be equal to or greater than the +3.3 VDC output at all times during power-up and normal operation. The time between the +12 VDC or +5 VDC output reaching its minimum in-regulation level and +3.3 VDC reaching its minimum in-regulation level must be  $\leq 20$  ms.

### 3.2.11. Voltage Hold-up Time

The power supply should maintain output regulation per Section 3.2.1 despite a loss of input power at the low-end nominal range—115 VAC / 57 Hz or 230 VAC / 47 Hz—at maximum continuous output load as applicable for a minimum of 17 ms.

### 3.3. Timing / Housekeeping / Control

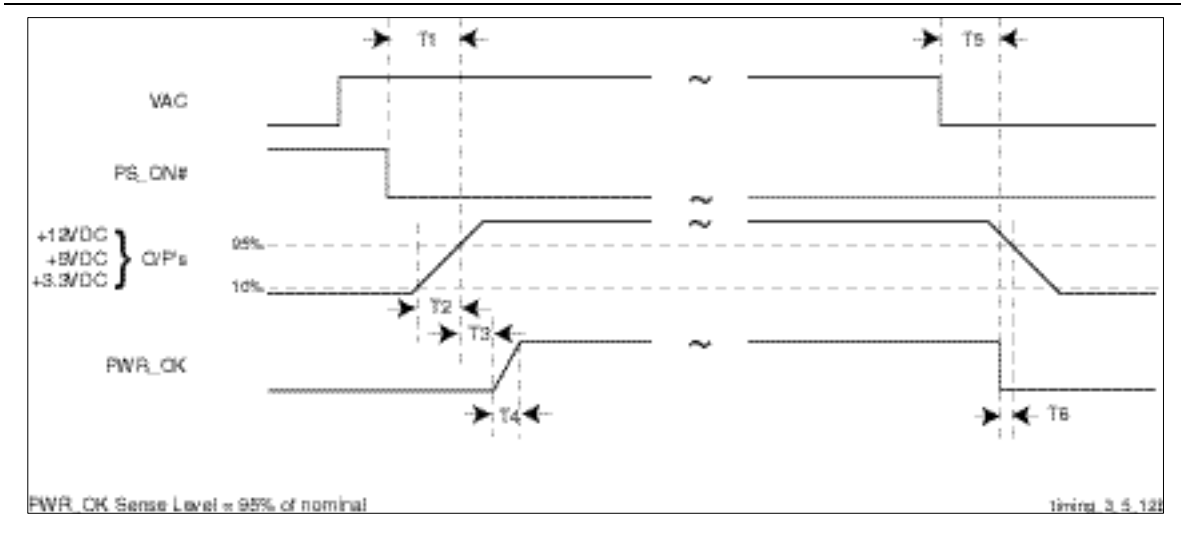

**Figure 2. Power Supply Timing**

Notes:

T1 is defined in Section 3.3.4.

T2 is defined in Section 3.3.5.

T3, T4, T5, and T6 are defined in Table 12

#### 3.3.1. PWR\_OK

PWR\_OK is a “power good” signal. This signal should be asserted high by the power supply to indicate that the +12 VDC, +5 VDC, and +3.3 VDC outputs are above the under voltage thresholds listed in Table 2 of Section 3.2.1 and that sufficient mains energy is stored by the converter to guarantee continuous power operation within specification for at least the duration specified in Section 3.2.11, “Voltage Hold-up Time.” Conversely, PWR\_OK should be de-asserted to a low state when any of the +12 VDC, +5 VDC, or +3.3 VDC output voltages falls below its under voltage threshold, or when mains power has been removed for a time sufficiently long such that power supply operation cannot be guaranteed beyond the power-down warning time. The electrical and timing characteristics of the PWR\_OK signal are given in Table 12 and in Figure 2.

**Table 12. PWR\_OK Signal Characteristics**

Signal Type	+5 V TTL compatible
Logic level low	< 0.4 V while sinking 4 mA
Logic level high	Between 2.4 V and 5 V output while sourcing 200 $\mu$ A
High-state output impedance	1 k $\Omega$ from output to common
PWR_OK delay	100 ms < T <sub>3</sub> < 500 ms
PWR_OK rise time	T <sub>4</sub> $\leq$ 10 ms
AC loss to PWR_OK hold-up time	T <sub>5</sub> $\geq$ 16 ms
Power-down warning	T <sub>6</sub> $\geq$ 1 ms

### 3.3.2. PS\_ON#

PS\_ON# is an active-low, TTL-compatible signal that allows a motherboard to remotely control the power supply in conjunction with features such as soft on/off, Wake on LAN<sup>†</sup>, or wake-on-modem. When PS\_ON# is pulled to TTL low, the power supply should turn on the four main DC output rails: +12 VDC, +5 VDC, +3.3 VDC, and -12 VDC. When PS\_ON# is pulled to TTL high or open-circuited, the DC output rails should not deliver current and should be held at zero potential with respect to ground. PS\_ON# has no effect on the +5 VSB output, which is always enabled whenever the AC power is present. Table 13 lists PS\_ON# signal characteristics.

The power supply shall provide an internal pull-up to TTL high. The power supply shall also provide de-bounce circuitry on PS\_ON# to prevent it from oscillating on/off at startup when activated by a mechanical switch. The DC output enable circuitry must be SELV-compliant.

The power supply shall not latch into a shutdown state when PS\_ON# is driven active by pulses between 10ms to 100ms during the decay of the power rails.

**Table 13. PS\_ON# Signal Characteristics**

Parameter	Minimum	Maximum.
V <sub>IL</sub> , Input Low Voltage	0.0 V	0.8 V
I <sub>IL</sub> , Input Low Current (V <sub>in</sub> = 0.4 V)		-1.6 mA
V <sub>IH</sub> , Input High Voltage (I <sub>in</sub> = -200 $\mu$ A)	2.0 V	
V <sub>IH</sub> open circuit, I <sub>in</sub> = 0		5.25 V

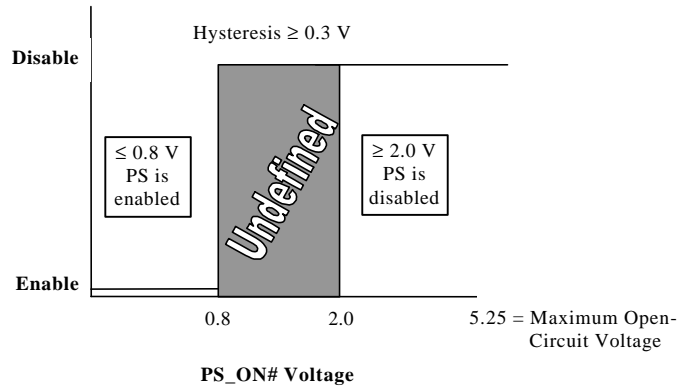

**Figure 3. PS\_ON# Signal Characteristics**

### 3.3.3. +5 VSB

+5 VSB is a standby supply output that is active whenever the AC power is present. This output provides a power source for circuits that must remain operational when the five main DC output rails are in a disabled state. Example uses include soft power control, Wake on LAN, wake-on-modem, intrusion detection, or suspend state activities.

The +5 VSB output should be capable of delivering a minimum of 1.0 A at  $+5\text{ V} \pm 5\%$  to external circuits. Because trends indicate a growing demand for standby power, it is recommended that designs be scalable to 2.0 A to meet future needs. The power supply must be able to provide the required power during a "wake up" event. If an external USB device generates the event, there may be peak currents as high as 2.5 A lasting no more than 500 ms.

Over current protection is required on the +5 VSB output regardless of the output current rating. This ensures the power supply will not be damaged if external circuits draw more current than the supply can provide.

### 3.3.4. Power-on Time

The power-on time is defined as the time from when PS\_ON# is pulled low to when the +12 VDC, +5 VDC, and +3.3 VDC outputs are within the regulation ranges specified in Section 3.2.1. The power-on time shall be less than 500 ms ( $T_1 < 500\text{ ms}$ ).

+5 VSB shall have a power-on time of two seconds maximum after application of valid AC voltages.

### 3.3.5. Rise Time

The output voltages shall rise from  $\leq 10\%$  of nominal to within the regulation ranges specified in Section 3.2.1 within 0.2 ms to 20 ms ( $0.2\text{ ms} \leq T_2 \leq 20\text{ ms}$ ).

There must be a smooth and continuous ramp of each DC output voltage from 10% to 90% of its final set point within the regulation band, while loaded as specified in Section 3.2.3. The smooth turn-on requires that, during the 10% to 90% portion of the rise time, the slope of the turn-on

waveform must be positive and have a value of between 0 V/ms and  $[V_{out, nominal} / 0.1]$  V/ms. Also, for any 5 ms segment of the 10% to 90% rise time waveform, a straight line drawn between the end points of the waveform segment must have a slope  $\geq [V_{out, nominal} / 20]$  V/ms.

### 3.3.6. Overshoot at Turn-on / Turn-off

The output voltage overshoot upon the application or removal of the input voltage, or the assertion/de-assertion of PS\_ON#, under the conditions specified in Section 3.1, shall be less than 10% above the nominal voltage. No voltage of opposite polarity shall be present on any output during turn-on or turn-off.

### 3.3.7. Reset after Shutdown

If the power supply latches into a shutdown state because of a fault condition on its outputs, the power supply shall return to normal operation only after the fault has been removed and the PS\_ON# has been cycled OFF/ON with a minimum OFF time of one second.

### 3.3.8. +5 VSB at AC Power-down

After AC power is removed, the +5 VSB standby voltage output should remain at its steady state value for the minimum hold-up time specified in Section 3.2.11 until the output begins to decrease in voltage. The decrease shall be monotonic in nature, dropping to 0.0 V. There shall be no other perturbations of this voltage at or following removal of AC power.

## 3.4. Output Protection

### 3.4.1. Over Voltage Protection

The over voltage sense circuitry and reference shall reside in packages that are separate and distinct from the regulator control circuitry and reference. No single point fault shall be able to cause a sustained over voltage condition on any or all outputs. The supply shall provide latch-mode over voltage protection as defined in Table 14.

**Table 14. Over Voltage Protection**

Output	Minimum	Nominal	Maximum	Unit
+12 VDC	13.4	15.0	15.6	Volts
+5 VDC	5.74	6.3	7.0	Volts
+3.3 VDC	3.76	4.2	4.3	Volts

### 3.4.2. Short-circuit Protection

An output short circuit is defined as any output impedance of less than 0.1 ohms. The power supply shall shut down and latch off for shorting the +3.3 VDC, +5 VDC, or +12 VDC rails to return or any other rail. Shorts between main output rails and +5 VSB shall not cause any damage to the power supply. The power supply shall either shut down and latch off or fold back

for shorting the negative rails. +5 VSB must be capable of being shorted indefinitely, but when the short is removed, the power supply shall recover automatically or by cycling PS\_ON#. The power supply shall be capable of withstanding a continuous short-circuit to the output without damage or overstress to the unit (for example, to components, PCB traces, and connectors) under the input conditions specified in Section 3.1.

### **3.4.3. No-load Operation**

No damage or hazardous condition should occur with all the DC output connectors disconnected from the load. The power supply may latch into the shutdown state.

### **3.4.4. Over Current Protection**

Overload currents applied to each tested output rail will cause the output to trip before reaching or exceeding 240 VA. For testing purposes, the overload currents should be ramped at a minimum rate of 10 A/s starting from full load.

### **3.4.5. Over-Temperature Protection**

As an option, the power supply may include an over-temperature protection sensor, which can trip and shut down the power supply at a preset temperature point. Such an overheated condition is typically the result of internal current overloading or a cooling fan failure. If the protection circuit is non-latching, then it should have hysteresis built in to avoid intermittent tripping.

### **3.4.6. Output Bypass**

The output return may be connected to the power supply chassis. The return will be connected to the system chassis by the system components.

## **4. Mechanical**

---

### **4.1. Labeling / Marking**

The following is a non-inclusive list of suggested markings for each power supply unit. Product regulation stipulations for sale into various geographies may impose additional labeling requirements.

- Manufacturer information: manufacturer's name, part number, and lot date code, etc., in human-readable text and/or bar code formats
- Nominal AC input operating voltages (100-127 VAC and 200-240 VAC) and current rating certified by all applicable safety agencies (see Section 7)
- DC output voltages and current ratings
- Access warning text (“Do not remove this cover. Trained service personnel only. No user serviceable components inside.”) in English, German, Spanish, French, Chinese, and Japanese with universal warning markings

## 4.2. Airflow / Fan

The designer's choice of a power supply cooling solution depends in part on the targeted end-use system application(s). At a minimum, the power supply design must ensure its own reliable and safe operation.

Fan location/direction. In general, exhausting air from the system chassis enclosure via a power supply fan at the rear panel is the preferred, most common, and most widely applicable system-level airflow solution. However, some system/chassis designers may choose to use other to meet specific system cooling requirements.

Fan size/speed. The SFX series has 40 mm, 60 mm, and 80 mm fan options. The 40 mm fan version is shown in Appendix A, Figure 5. Appendix B, Figure 7 details an 80 mm top mounted fan version. Appendix C, Figure 10 features the 80 mm top mounted, reduced depth fan for the SFX12V. The standard SFX has a 60 mm axial fan shown in Appendix D, Figure 12. It is recommended that a thermally sensitive fan speed control circuit be used to balance system-level thermal and acoustic performance. The circuit typically senses the temperature of the secondary heatsink and/or incoming ambient air and adjusts the fan speed as necessary to keep power supply and system component temperatures within specification. Both the power supply and system designers should be aware of the dependencies of the power supply and system temperatures on the control circuit response curve and fan size and should specify them carefully.

The power supply fan should be turned off when PS\_ON# is de-asserted (high). In this state, any remaining active power supply circuitry must rely only on passive convection for cooling.

Venting. In general, more venting in a power supply case yields reduced airflow impedance and improved cooling performance. Intake and exhaust vents should be large, open, and unobstructed as possible so as not to impede airflow or generate excessive acoustic noise. In particular, avoid placing objects within 0.5 inches of the intake or exhaust of the fan itself. A flush-mount wire fan grill can be used instead of a stamped metal vent for improved airflow and reduced acoustic noise.

The limitations to the venting guidelines above are:

- Openings must be sufficiently designed to meet the safety requirements described in Section 7.
- Larger openings yield decreased EMI-shielding performance (see Section 6).
- Venting in inappropriate locations can detrimentally allow airflow to bypass those areas where it is needed.

## 4.3. AC Connector

The AC input receptacle should be an IEC 320 type or equivalent. In lieu of a dedicated switch, the IEC 320 receptacle may be considered the mains disconnect.

## 4.4. DC Connectors

Figure 4 shows pin outs and profiles for typical SFX power supply DC harness connectors. The SFX12V requires an additional two-pin, power connector.

UL Listed or recognized component appliance wiring material rated min 85 °C, 300 VDC shall be used for all output wiring.

There are no specific requirements for output wire harness lengths, as these are largely a function of the intended end-use chassis, motherboard, and peripherals. Ideally, wires should be short to minimize electrical/airflow impedance and simplify manufacturing, yet they should be long enough to make all necessary connections without any wire tension (which can cause disconnections during shipping and handling). Recommended minimum harness lengths for general-use power supplies is 150 mm for all wire harnesses. Measurements are made from the exit port of the power supply case to the wire side of the first connector on the harness.

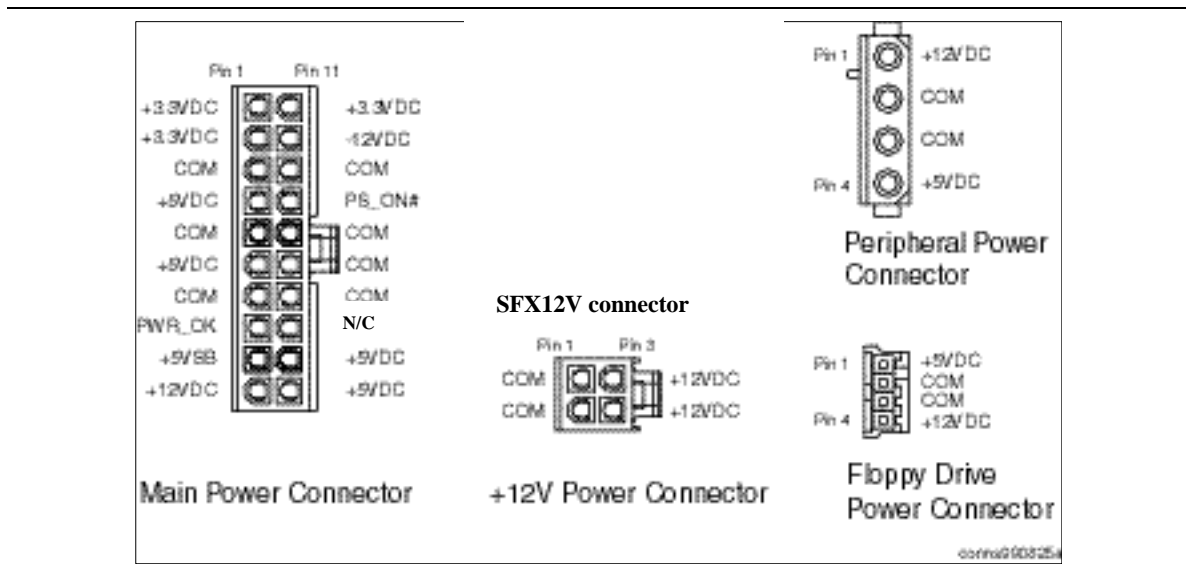

**Figure 4. SFX/SFX12V Connectors**

(Pin-side view, not to scale)

#### 4.4.1. SFX Main Power Connector

**Connector: MOLEX 39-01-2200 or equivalent**

(Mating motherboard connector is Molex 39-29-9202 or equivalent)

18 AWG is suggested for all wires except for the +3.3 V supply and sense return wires combined into pin 11 (22 AWG).

Pin	Signal	Color	Pin	Signal	Color
1	+3.3 VDC	Orange	11	+3.3 VDC	Orange
			[11]	[+3.3 V default sense]	[Brown]
2	+3.3 VDC	Orange	12	-12 VDC	Blue
3	COM	Black	13	COM	Black
4	+5 VDC	Red	14	PS_ON#	Green
5	COM	Black	15	COM	Black
6	+5 VDC	Red	16	COM	Black
7	COM	Black	17	COM	Black
8	PWR_OK	Gray	18	Reserved	NC
9	+5 VSB	Purple	19	+5 VDC	Red
10	+12 VDC	Yellow	20	+5 VDC	Red

#### 4.4.2. Peripheral Connector(s)

**Connector: AMP 1-480424-0 or MOLEX 8981-04P or equivalent.**

**Contacts: AMP 61314-1 or equivalent.**

Pin	Signal	18 AWG Wire
1	+12 VDC	Yellow
2	COM	Black
3	COM	Black
4	+5 VDC	Red

#### 4.4.3. Floppy Drive Connector

**Connector: AMP 171822-4 or equivalent**

Pin	Signal	20 AWG Wire
1	+5 VDC	Red
2	COM	Black
3	COM	Black
4	+12 VDC	Yellow

#### 4.4.4. +12 V Power Connector (for SFX12V only)

**Connector: MOLEX 39-01-2040 or equivalent**

(Mating motherboard connector is Molex 39-29-9042 or equivalent)

Pin	Signal	20 AWG Wire	Pin	Signal	20 AWG Wire
1	COM	Black	3	+12 VDC	Yellow
2	COM	Black	4	+12 VDC	Yellow

## 5. Environmental

---

The following subsections define recommended environmental specifications and test parameters, based on the typical conditions to which an SFX and power supply may be subjected during operation or shipment.

### 5.1. Temperature

Operating ambient      +10 °C to +50 °C (At full load, with a maximum temperature rate of change of 5 °C/10 minutes, but no more than 10 °C/hr.)

Non-operating ambient      -40 °C to +70 °C (Maximum temperature rate of change of 20 °C/hr.)

### 5.2. Thermal Shock (Shipping)

Non-operating                      -40 °C to +70 °C

15 °C/min ≤ dT/dt ≤ 30 °C/min

Tested for 50 cycles; Duration of exposure to temperature extremes for each half cycle shall be 30 minutes.

### 5.3. Humidity

Operating                              To 85% relative humidity (non-condensing)

Non-operating                      To 95% relative humidity (non-condensing)

Note: 95% RH is achieved with a dry bulb temperature of 55 °C and a wet bulb temperature of 54 °C.

### 5.4. Altitude

Operating      To 10,000 ft

Non-operating To 50,000 ft

### 5.5. Mechanical Shock

Non-operating                      50 g, trapezoidal input; velocity change ≥ 170 in/s

Three drops on each of six faces are applied to each sample.

## 5.6. Random Vibration

Non-operating                      0.01 g<sup>2</sup>/Hz at 5 Hz, sloping to 0.02 g<sup>2</sup>/Hz at 20 Hz, and maintaining 0.02 g<sup>2</sup>/Hz from 20 Hz to 500 Hz. The area under the PSD curve is 3.13 gRMS. The duration shall be 10 minutes per axis for all three axes on all samples.

## 5.7. Acoustics

Sound Pressure: The power supply assembly shall not produce a sound pressure level greater than 40 db(A) in a 1/3 octave frequency band, when measured over the frequency range of 100 to 10 kHz at 35°C ambient at one half load. Sound pressure determination is to be performed in accordance with ISO 7779.

Pure Tones: The maximum permissible sound pressure variation between adjacent 1/3 octave bands may not exceed 10 db(A). Sound pressure determination to be performed in accordance with ISO 7779

## 5.8. Ecological Requirements

The following materials must not be used during design and/or manufacturing of this product:

- Cadmium shall not be used in painting or plating.
- No Quaternary salt or PCB electrolytic capacitors shall not be used.
- CFC's or HFC's shall not be used in the design or manufacturing process.
- Mercury shall not be used.

## 6. Electromagnetic Compatibility

---

The following subsections outline applicable product regulatory requirements for the SFX12/SFX12V power supply. Additional requirements may apply dependent upon the design, product end use (e.g., medical equipment and hazardous locations), target geography, and other variables.

### 6.1. Emissions

The power supply shall comply with FCC Part 15, EN22022: 1998 and CISPR 22, 3<sup>rd</sup> ed., meeting Class B for both conducted and radiated emissions with a 4 dB margin. Tests shall be conducted using a shielded DC output cable to a shielded load. The load shall be adjusted as follows for three tests: No load on each output; 50% load on each output; 100% load on each output. Tests will be performed at 100 VAC 50Hz, 120 VAC 60 Hz, and 230 VAC 50 Hz power. Additionally, for FCC certification purposes, the power supply shall be tested using the methods in 47 CFR 15.32(b) and authorized under the Declaration of Conformity process as defined in 47 CFR 2.906 using the process in 47 CFR 2.1071 through 47 CFR 2.1077.

#### 6.1.2 Immunity

The power supply shall comply with EN 55024:1998 and CISPR 24 prior to sale in the EU (European Union), Korea, and possibly other geographies

### 6.2. Input Line Current Harmonic Content

For sales in EU (European Union) the power supply shall meet the requirements of EN61000-3-2 Class D and the Guidelines for the Suppression of Harmonics in Appliances and General Use Equipment Class D for harmonic line current content at full rated power. See Table 15 for the harmonic limits.

**Table 15: Harmonic Limits, Class D equipment**

	<i>Per: EN 61000-3-2</i>	<i>Per: JEIDA MITI</i>
Harmonic Order n	Maximum permissible Harmonic current at <u>230 VAC / 50 Hz</u> in Amps	Maximum permissible Harmonic current at <u>100VAC / 50 Hz</u> in Amps
	Odd harmonics	
3	2.3	5.29
5	1.14	2.622
7	0.77	1.771
9	0.4	0.92
11	0.33	0.759
13	0.21	0.483
15 ≤ n ≤ 39	0.15 x (15/n)	0.345 x (15/n)

### 6.3. Magnetic Leakage Fields

A PFC choke magnetic leakage field should not cause any interference with a high-resolution computer monitor placed next to or on top of the end-use chassis.

### 6.4. Reliability

The derating process promotes quality and high reliability. All electronic components should be designed with conservative device deratings for use in commercial and industrial environments.

### 6.5. Mean Time Between Failures (MTBF)

The MTBF of the power supply can be calculated with the Part-Stress Analysis method of MIL-HDBK-217F using the quality factors listed in MIL-HDBK-217F. A target calculated MTBF of the power supply is greater than 100,000 hours under the following conditions:

- 75 % of Full-rated load
- 120 VAC input
- Ground benign

## 6.6. Voltage Fluctuations and Flicker

The power supply shall meet the specified limits of EN61000-3-3 for voltage fluctuations and flicker for equipment drawing not more than 16AAC, connected to low voltage distribution systems.

## 7. Safety

---

The following subsections outline sample product regulations requirements for a typical power supply. Actual requirements will depend on the design, product end use, target geography, and other variables. Consult your company's Product Safety and Regulations department for more details.

### 7.1. North America

The power supply must be certified by an NRTL (Nationally Recognized Testing Laboratory) for use in the USA and Canada under the following conditions:

- The supply must be Recognized for use in Information Technology Equipment including Electrical Business Equipment per UL 1950 / CAN/CSA C22.2 No. 950-95, renamed UL 60950, 3<sup>rd</sup> edition, without D3 deviations. The certification must include external enclosure testing for the AC receptacle side of the power supply (see Appendix A, B, C, and D).
- The supply must have a full complement of tests conducted as part of the certification, such as input current, leakage current, hi-pot, temperature, energy discharge test, transformer output characterization test (open-circuit voltage, short-circuit current, and maximum VA output), and abnormal testing (to include stalled-fan tests and voltage-select-switch mismatch).
- The enclosure must meet fire enclosure mechanical test requirements per clauses 2.9.1 and 4.2 of the above-mentioned standard.

100% production hipot testing must be included and marked as such on the power supply enclosure.

There must not be unusual or difficult conditions of acceptability such as mandatory additional cooling or power derating. The insulation system shall not have temperatures exceeding their rating when tested in the end product.

The certification mark shall be marked on each power supply.

The power supply must be evaluated for operator-accessible secondary outputs (reinforced insulation) that meet the requirements for SELV and do not exceed 240 VA under any condition of loading.

The proper polarity between the AC input receptacle and any printed wiring boards connections must be maintained (that is, brown=line, blue=neutral, and green=earth/chassis).

Failure of any single component in the fan-speed control circuit shall not cause the internal component temperatures to exceed the abnormal fault condition temperatures per IEC 60950.

## 7.2. International

The vendor must provide a complete CB certificate and test report to IEC 60950:1991, 2<sup>nd</sup> edition + A1, A2, A3, and A4. The CB report must include ALL CB member country national deviations. CB report must include evaluation to EN 60950:1992, + A1, A2, A3, A4 and Nordic deviations EMKO-TSE (74-SEC) 207/94.

All evaluations and certifications must be for reinforced insulation between primary and secondary circuits.

## 8. SYSTEM COOLING CONSIDERATIONS

---

The fan location allows the system designer to utilize the airflow to help cool critical components such as the processor and chipset without adding a second system fan. This will reduce acoustic noise and system cost. Please note that the fan pulls air from the system, instead of blowing hot air into the system, so components must be placed such that airflow is directed across critical components. Cables, etc must not impede airflow.

However, it should be noted that a processor active heat sink might still be necessary because of the limited amount of airflow that this type of power supply can deliver. For more information on system thermal design, please refer to [www.formfactors.org](http://www.formfactors.org)

## **APPENDIX A      GUIDELINES FOR A LOWER PROFILE PACKAGE**

---

### **A.1 OVERVIEW**

For applications requiring a lower profile, such as a network PC or slim desktop chassis, the power supply PCB could be repackaged in an enclosure 50 mm in height. This would allow an internal 40 mm fan to be installed for power supply cooling. This power supply would differ only in the mechanical outline specifications.

### **A.2 PHYSICAL DIMENSIONS**

The supply shall be enclosed and meet the physical outline shown in Figure 5.

### **A.3 FAN REQUIREMENTS**

The fan will draw air from the computer system cavity pressurizing the power supply enclosure. The power supply enclosure shall exhaust the air through a grill located on the rear panel. See Figure 6. The movement of the fan to the computer system cavity is to help limit the acoustic noise of the unit.

The fan will be 40 mm.

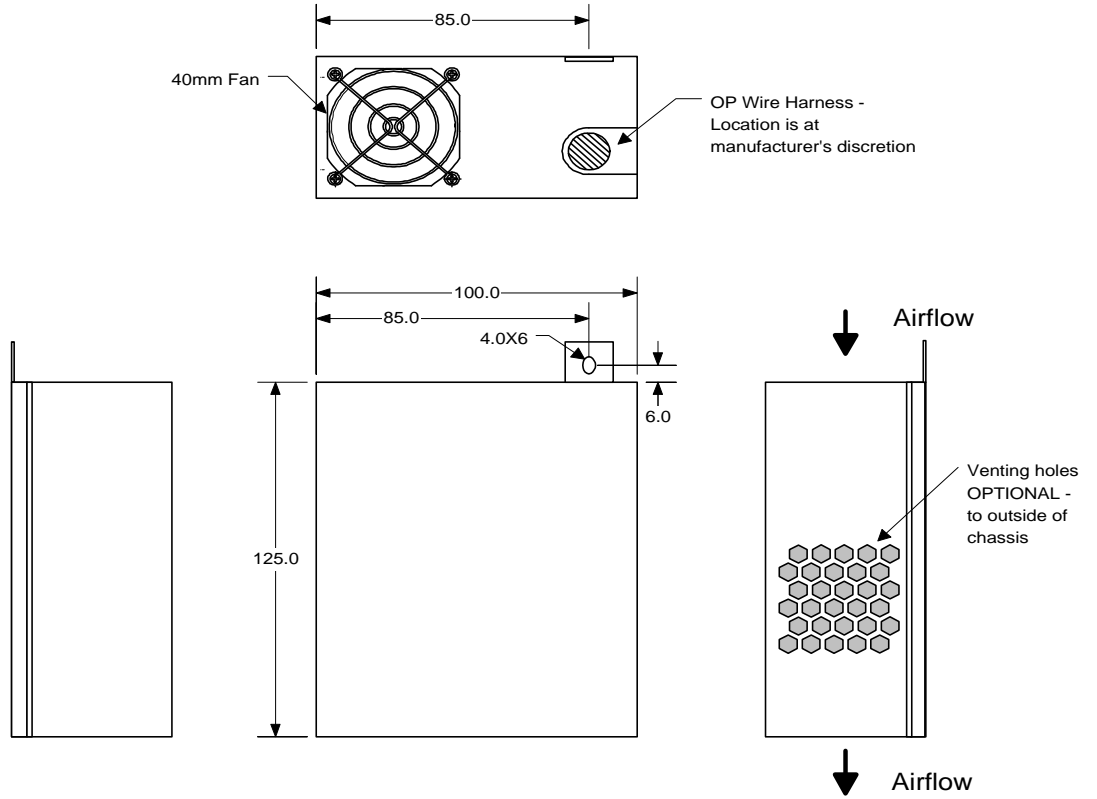

- Notes:
1. Unless otherwise specified, all dimensions are in mm.  
Tolerance:  
Whole No.: XX +/- 1  
Decimal No.: X.X +/- 0.5
  2. Do not scale drawing.
  3. A stamped SM fan guard may be used subject to approval.

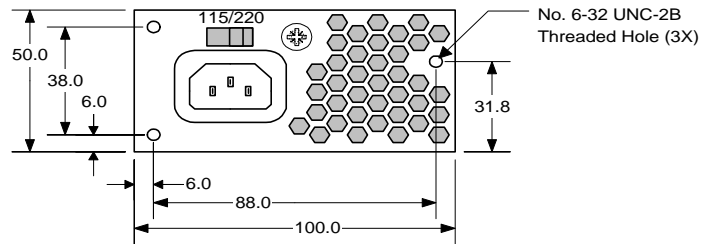

**Figure 5 40 mm Profile Mechanical Outline**

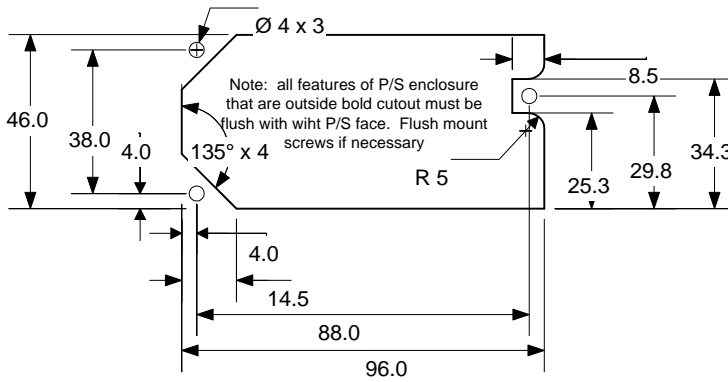

**Figure 6 Chassis Cutout**

## **APPENDIX B      GUIDELINES FOR A TOP MOUNT FAN PACKAGE**

---

### **B.1      OVERVIEW**

For applications requiring greater airflow directed 90° to the power supply top cover, such as a microATX or mini-tower chassis, the power supply PCB could be repackaged in an enclosure with an 80 mm fan mounted to the top cover. This would provide greater flow of cooling air with better directed cooling. This power supply would differ only in the mechanical outline specifications.

### **B.2      PHYSICAL DIMENSIONS**

The supply shall be enclosed and meet the physical outline shown in Figure 7.

### **B.3      FAN REQUIREMENTS**

The fan will draw air from the computer system cavity pressurizing the power supply enclosure. The power supply enclosure shall exhaust the air through a grill located on the rear panel. See Figure 8. Moving the fan to the computer system cavity helps to limit the acoustic noise of the unit.

The fan will be 80mm.

To prevent damage to the fan during shipment and handling, the power supply designer should consider recessing the fan mounting, as shown in Figure 9.

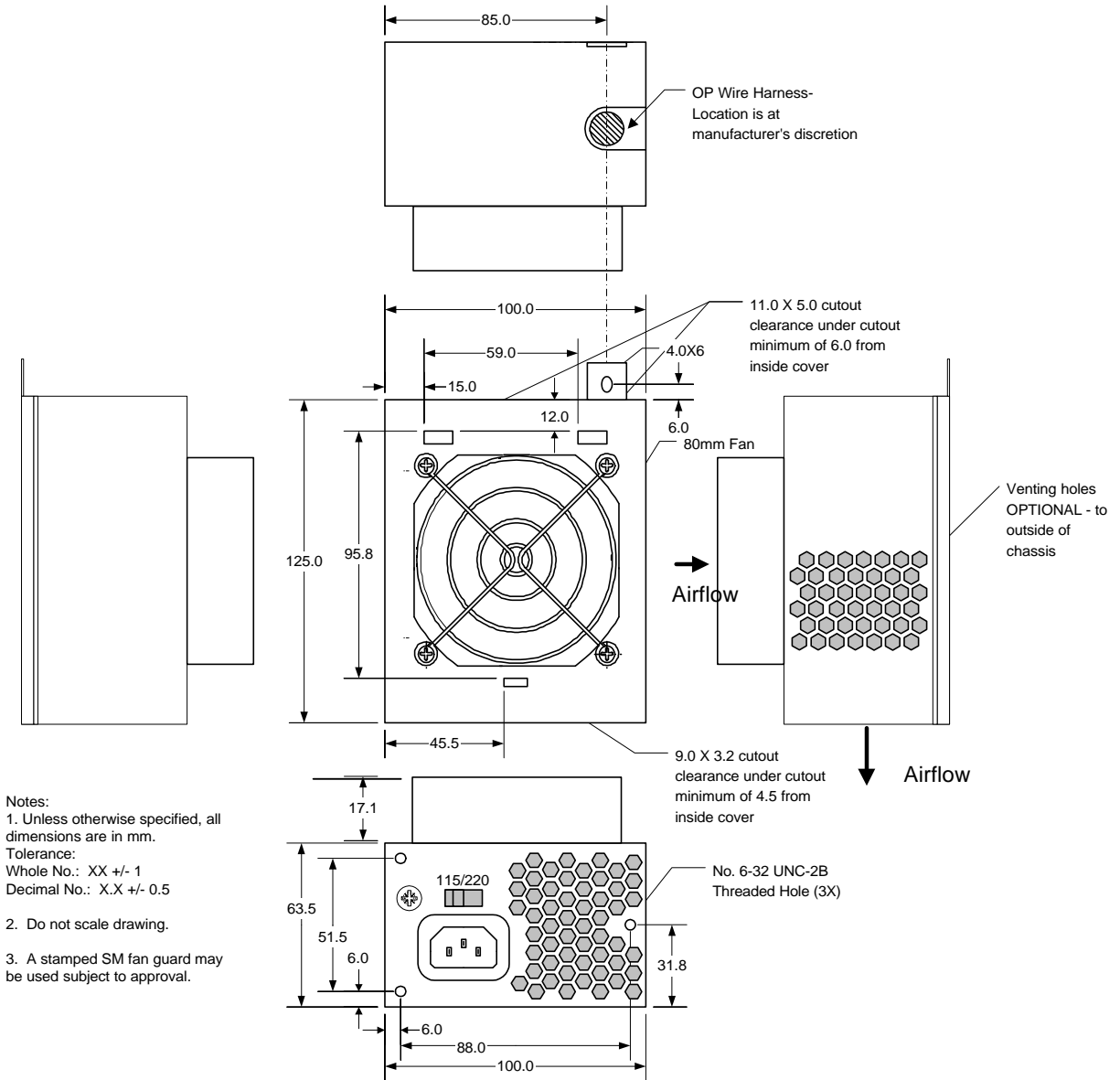

**Figure 7 Top Mount Fan Profile Mechanical Outline**

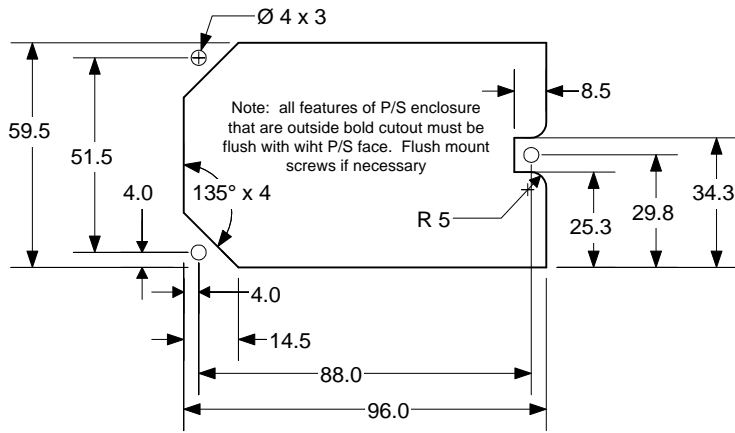

**Figure 8 Chassis Cutout**

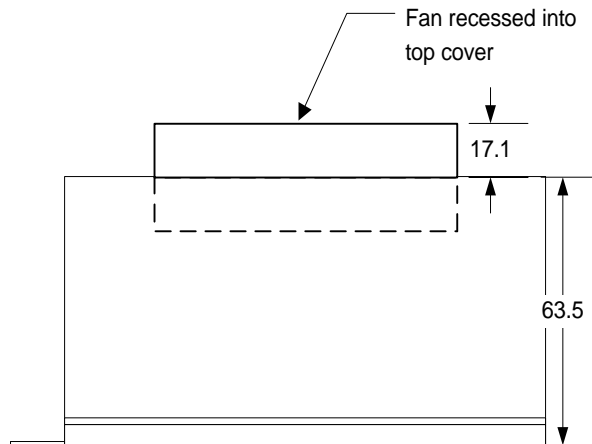

**Figure 9 Recessed Fan Mounting**

## **APPENDIX C      GUIDELINES FOR A REDUCED DEPTH, TOP MOUNT FAN PACKAGE**

---

### **C.1      OVERVIEW**

For applications requiring greater airflow directed 90° to the power supply top cover, such as a microATX or mini-tower chassis, with reduced depth, the power supply PCB could be repackaged in an enclosure with an 80 mm fan mounted to the top cover, with the length and depth dimensions rotated 90°. This provides greater flow of cooling air with better directed cooling. This power supply would differ only in the mechanical outline specifications.

### **C.2      PHYSICAL DIMENSIONS**

The supply shall be enclosed and meet the physical outline shown in Figure 10.

### **C.3      FAN REQUIREMENTS**

The fan will draw air from the computer system cavity pressurizing the power supply enclosure. The power supply enclosure shall exhaust the air through a grill located on the rear panel. See Figure 11. Moving the fan to the computer system cavity helps to limit the acoustic noise of the unit.

The fan will be 80 mm.

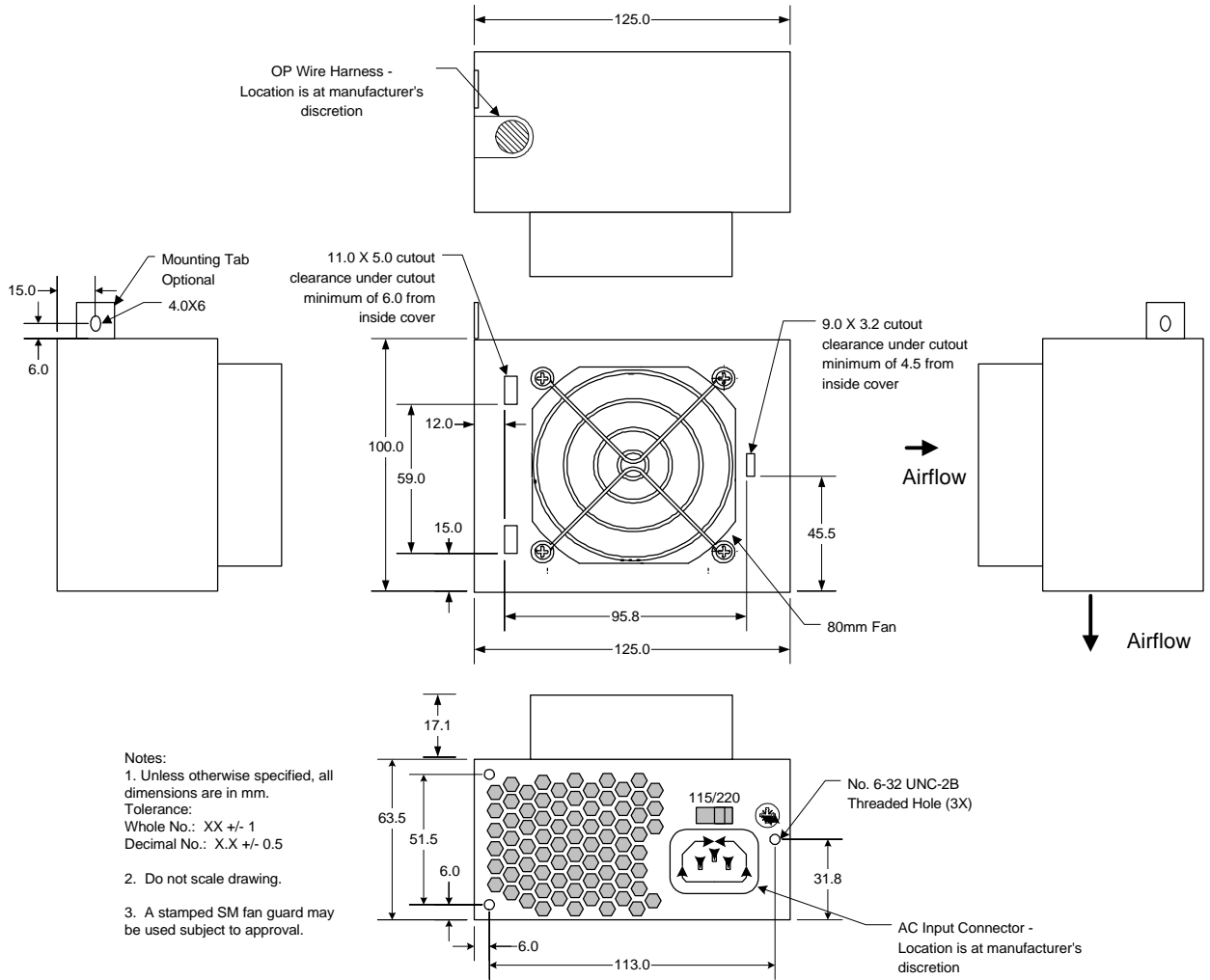

**Figure 10 Reduced Depth Top Mount Fan Profile Mechanical Outline**

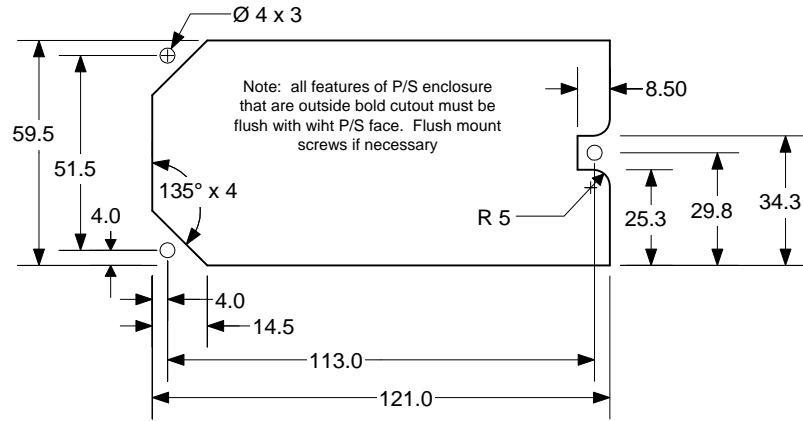

**Figure 11 Chassis cutout**

## **APPENDIX D      GUIDELINES FOR A LOWER PROFILE PACKAGE**

---

### **D.1 OVERVIEW**

For applications using the standard SFX profile.

### **D.2 PHYSICAL DIMENSIONS**

The supply shall be enclosed and meet the physical outline shown in Figure 12.

### **D.3 FAN REQUIREMENTS**

The fan will draw air from the computer system cavity pressurizing the power supply enclosure. The power supply enclosure shall exhaust the air through a grill located on the rear panel. See Figure 13. Moving the fan to the computer system cavity helps to limit the acoustic noise of the unit.

The fan will be 60 mm.

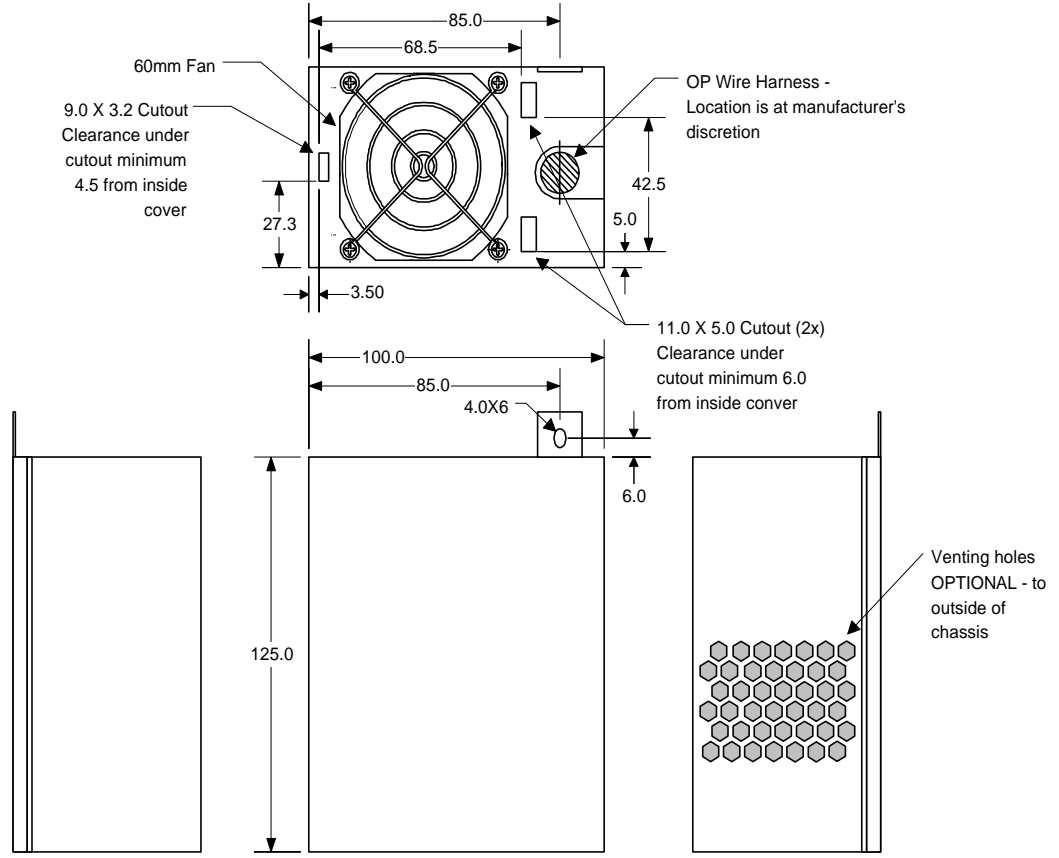

- Notes:
1. Unless otherwise specified, all dimensions are in mm.  
Tolerance:  
Whole No.: XX +/- 1  
Decimal No.: X.X +/- 0.5
  2. Do not scale drawing.
  3. A stamped SM fan guard may be used subject to approval.

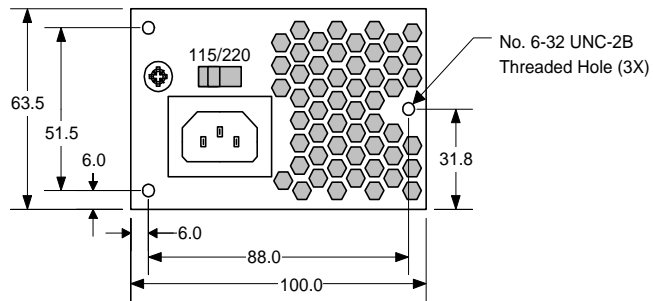

**Figure 12 60 mm Mechanical Outline**

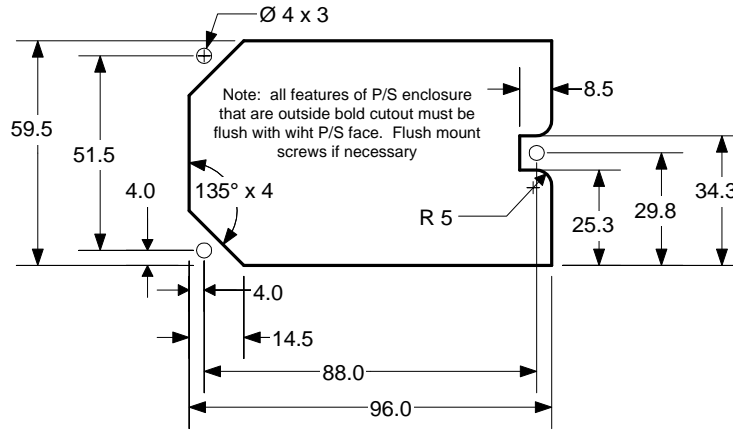

**Figure 13 Chassis Cutout**