

LFX12V

Lowprofile Form Factor with 12-Volt Connector

Power Supply Design Guide

Version 1.0

Revision History

Version	Release Date	Notes	
1.0	April, 2004	<ul style="list-style-type: none">First public release.	

LFX12V Power Supply Design Guide

Lowprofile Form Factor with 12-Volt Connector

IMPORTANT INFORMATION AND DISCLAIMERS

INTEL CORPORATION (AND ANY CONTRIBUTOR) IS PROVIDING THIS INFORMATION AS A CONVENIENCE AND ACCORDINGLY MAKES NO WARRANTIES WITH REGARD TO THIS DOCUMENT OR PRODUCTS MADE IN CONFORMANCE WITH THIS DOCUMENT.

THIS DOCUMENT IS PROVIDED "AS IS" AND INTEL DISCLAIMS ALL EXPRESS AND IMPLIED WARRANTIES, INCLUDING THE WARRANTY OF MERCHANTABILITY AND FITNESS FOR PARTICULAR PURPOSE. IN ADDITION, INTEL (AND ANY CONTRIBUTOR) DOES NOT WARRANT OR REPRESENT THAT THIS DOCUMENT OR ANY PRODUCTS MADE IN CONFORMANCE WITH IT WILL OPERATE IN THE INTENDED MANNER, ARE FREE FROM ERRORS OR DEFECTS, OR ARE SAFE FOR USE FOR ITS INTENDED PURPOSE. ANY PERSON USING THIS DOCUMENT OR MAKING, USING, OR SELLING PRODUCTS IN CONFORMANCE WITH THIS DOCUMENT DOES SO AT HIS OR HER OWN RISK.

INTEL DISCLAIMS ALL LIABILITY ARISING FROM OR RELATED TO USE OR IMPLEMENTATION OF THE INFORMATION PROVIDED IN THIS DOCUMENT, INCLUDING LIABILITY FOR INFRINGEMENT OF ANY INTELLECTUAL PROPERTY RIGHTS RELATING TO THE INFORMATION OR THE IMPLEMENTATION OF INFORMATION IN THIS DOCUMENT. INTEL DOES NOT WARRANT OR REPRESENT THAT SUCH DEVICES OR IMPLEMENTATION WILL NOT INFRINGE SUCH RIGHTS.

INTEL IS NOT OBLIGATED TO PROVIDE ANY SUPPORT, INSTALLATION OR OTHER ASSISTANCE WITH REGARD TO THE INFORMATION OR PRODUCTS MADE IN ACCORDANCE WITH IT. THE INFORMATION IN THIS DOCUMENT IS SUBJECT TO CHANGE WITHOUT NOTICE.

THE INFORMATION REFERRED TO IN THIS DOCUMENT IS INTENDED FOR STANDARD COMMERCIAL USE ONLY. CUSTOMERS ARE SOLELY RESPONSIBLE FOR ASSESSING THE SUITABILITY OF THE INFORMATION FOR USE IN PARTICULAR APPLICATIONS. THE INFORMATION IS NOT INTENDED FOR USE IN CRITICAL CONTROL OR SAFETY SYSTEMS, MEDICAL OR LIFE SAVING APPLICATIONS, OR IN NUCLEAR FACILITY APPLICATIONS.

NO LICENSE, EXPRESS OR IMPLIED, BY ESTOPPEL OR OTHERWISE, TO ANY INTELLECTUAL PROPERTY RIGHTS IS GRANTED HEREIN.

Intel and Pentium are trademarks or registered trademarks of Intel Corporation or its subsidiaries in the United States and other countries.

*Other names and brands may be claimed as the property of others.

Copyright © Intel Corporation 2004

Contents

1	Introduction	6
1.1	Scope	6
1.2	Terminology	6
2	Electrical	7
2.1	AC Input	7
2.1.1	Input Over Current Protection	8
2.1.2	Inrush Current Limiting	8
2.1.3	Input Under Voltage	8
2.1.4	Regulatory	8
2.1.5	Catastrophic Failure Protection	9
2.2	DC Output	10
2.2.1	DC Voltage Regulation	10
2.2.2	Remote Sensing	10
2.2.3	Typical Power Distribution	11
2.2.4	Power Limit / Hazardous Energy Levels	13
2.2.5	Efficiency General	13
2.2.6	Output Ripple/Noise	14
2.2.7	Output Transient Response	16
2.2.8	Capacitive Load	19
2.2.9	Closed-loop Stability	19
2.2.10	+5 VDC / +3.3 VDC Power Sequencing	19
2.2.11	Voltage Hold-up Time	19
2.3	Timing / Housekeeping / Control	20
2.3.1	PWR_OK	20
2.3.2	PS_ON#	21
2.3.3	+5 VSB	22
2.3.4	Power-on Time	22
2.3.5	Rise Time	22
2.3.6	Overshoot at Turn-on / Turn-off	22
2.3.7	Reset after Shutdown	23
2.3.8	+5 VSB at AC Power-down	23
2.4	Output Protection	23
2.4.1	Over Voltage Protection	23
2.4.2	Short-circuit Protection	23
2.4.3	No-load Operation	24
2.4.4	Over Current Protection	24
2.4.5	Over-temperature Protection	24
2.4.6	Output Bypass	24
3	Mechanical	25
3.1	Labeling /Marking	25
3.2	Physical Dimensions	25
3.2	AC Connector	29
3.3	DC Connectors	29

3.3.1	Main Power Connector	31
3.3.2	Peripheral Connector(s)	31
3.3.3	Floppy Drive Connector	32
	+12 V Power Connector	32
3.3.4	Serial ATA Power Connector.....	32
4	Thermal Requirements	33
4.1	Fan and Venting.....	33
4.2	Airflow and Acoustics	33
4.3	Airflow / Fan	35
5	Environmental	37
5.1	Temperature.....	37
5.2	Thermal Shock (Shipping).....	37
5.3	Relative Humidity	37
5.4	Altitude Requirement.....	37
5.5	Mechanical Shock.....	37
5.6	Random Vibration	38
5.7	Acoustics.....	38
5.8	Ecological Requirements	38
6	Safety.....	39
6.1	North America	39
6.2	International	40
7	System Cooling Considerations.....	41
8	Reliability	42
9	Applicable Documents	43

Figures

Figure 1: Cross Loading Graph for 180W configuration	11
Figure 2: Cross Loading Graph for 200W Configuration.....	12
Figure 3: Differential Noise Test Setup	16
Figure 4: Power Supply Timing.....	20
Figure 5: PS_ON# Signal Characteristics.....	21
Figure 6: Mechanical Outline	26
Figure 7: Mechanical Details.....	27
Figure 8: PSU Slot Feature Detail.....	28
Figure 9: Recommended Chassis Tab Feature	29
Figure 10: Connectors (Pin-side view, not to scale)	30
Figure 11: Serial ATA Connector	32
Figure 12: AMCA* Standard 210	35

Tables

Table 1. AC Input Line Requirements.....	8
Table 2. DC Output Voltage Regulation.....	10
Table 3. Typical Power Distribution for 180 W Configurations.....	11
Table 4. Typical Power Distribution for 200 W Configurations.....	12
Table 5. Efficiency Vs Load	13
Table 6. Loading Tables for Efficiency Measurements	13
Table 7. Energy Star* Input Power Consumption.....	14
Table 8. DC Output Noise/Ripple.....	16
Table 9. DC Output Transient Step Sizes	18
Table 10. Output Capacitive Loads.....	19
Table 11. PWR_OK Signal Characteristics.....	20
Table 12. PS_ON# Signal Characteristics	21
Table 13. Over Voltage Protection.....	23
Table 14. Airflow and Acoustic Recommendations.....	34
Table 15. Loading for Acoustic Test for 180 Watts	34
Table 16. Loading for Acoustic Test for 200 Watts	34

1 Introduction

1.1 Scope

This document provides design suggestions for power supply(s) that support Balanced Technology Extended (BTX) form factor systems. The power supply(s) are primarily intended for use with ultra small form factor system designs (6 –9 liters in total system volume). It should not be inferred that all power supplies built to support Balanced Technology Extended based systems must conform exactly to the content of this document, though there are key parameters that define mechanical fit across a common set of platforms. Since power supply needs vary depending on system configuration, the design specifics described are not intended to support all possible systems.

1.2 Terminology

The following terms are used in this document:

Term	Description
Required	The status given to items within this design guide, which are required to meet design guide and a large majority of system applications.
Recommended	The status given to items within this design guide, which are not required to meet design guide, however, are required by many system applications.
Optional	The status given to items within this design guide, which are not required to meet design guide, however, some system applications may optionally use these features.
B_A	Declared sound power, LwAd. The declared sound power level shall be measured according to ISO* 7779 for the power supply and reported according to ISO 9296.
CFM	Cubic Feet per Minute (airflow).
Monotonically	A waveform changes from one level to another in a steady fashion, without oscillation.
Noise	The periodic or random signals over frequency band of 0 Hz to 20 MHz.

Term	Description
Overcurrent	A condition in which a supply attempts to provide more output current than the amount for which it is rated. This commonly occurs if there is a "short circuit" condition in the load attached to the supply.
PFC	Power Factor Corrected.
Ripple	The periodic or random signals over a frequency band of 0 Hz to 20 MHz.
Rise Time	Rise time is defined as the time it takes any output voltage to rise from 10% to 95% of its nominal voltage.
Surge	The condition where the AC line voltage rises above nominal voltage.
VSB or Standby Voltage	An output voltage that is present whenever AC power is applied to the AC inputs of the supply.
MTBF	Mean time between failure.
PWR_OK	PWR_OK is a "power good" signal used by the system power supply to indicate that the +5VDC, +3.3 VDC and +12VDC outputs are above the undervoltage thresholds of the power supply.

2 Electrical

The following electrical requirements are required and must be met over the environmental ranges as defined in Section 5 (unless otherwise noted).

2.1 AC Input

Table 1, lists AC input voltage and frequency requirements for continuous operation. The power supply shall be capable of supplying full-rated output power over the voltage ranges shown in Table 1. The correct input range for use in a given environment may be either switch-selectable or auto-ranging. The power supply shall automatically recover from AC power loss. The power supply must be able to start up under peak loading at 90 VAC.

Table 1. AC Input Line Requirements

Parameter	Minimum	Nominal ⁽¹⁾	Maximum	Unit
V _{in} (115 VAC)	90	115	135	VAC _{rms}
V _{in} (230 VAC)	180	230	265	VAC _{rms}
V _{in} Frequency	47	--	63	Hz
I _{in} (115 VAC)			6	A rms
I _{in} (230 VAC)			3	A rms

Note: ⁽¹⁾ Nominal voltages for test purposes are considered to be within ± 1.0 V of nominal.

2.1.1 Input Over Current Protection

The power supply is required to incorporate primary fusing for input over current protection to prevent damage to the power supply and meet product safety requirements. Fuses should be slow-blow-type or equivalent to prevent nuisance trips.¹

2.1.2 Inrush Current Limiting

Maximum inrush current from power-on (with power-on at any point on the AC sine) and including, but not limited to, three line cycles, shall be limited to a level below the surge rating of the input line cord, AC switch if present, bridge rectifier, fuse, and EMI filter components. Repetitive ON/OFF cycling of the AC input voltage should not damage the power supply or cause the input fuse to blow.

2.1.3 Input Under Voltage

The power supply is required to contain protection circuitry such that the application of an input voltage below the minimum specified in Section 2.1, Table 1, shall not cause damage to the power supply.

2.1.4 Regulatory

The power supply is required to be tested and comply with the most current version of the following regulatory specification requirements and/or standards

2.1.4.1 PRODUCT SAFETY

UL* 60950, 3rd Edition –CAN/CSA-C22.2-60950-00,

EN*60 950, 3rd Edition

IEC*60 950, 3rd Edition (CB Report to include all national deviations)

¹ For Denmark and Switzerland international safety requirements, if the internal over current protective devices exceed 8A for Denmark and 10A for Switzerland, then the power supply must pass international safety testing to EN 60950 using a maximum 16A over-current protected branch circuit, and this 16A (time delay fuse) branch circuit protector must not open during power supply abnormal operation (output short circuit and component fault) testing.

EU* Low Voltage Directive (73/23/EEC) (CE Compliance)

GB4943-90 CCIB* (China)

2.1.4.2 ELECTROMAGNETIC COMPATIBILITY

FCC*, Class B, Part 15 (Radiated & Conducted Emissions)

CISPR* 22 / EN55022, 3rd Edition (Radiated & Conducted Emissions)

EN55024 (ITE Specific Immunity)

EN 61000-4-2 – Electrostatic Discharge

EN 61000-4-3– Radiated RFI Immunity

EN 61000-4-4– Electrical Fast Transients.

EN 61000-4-5 – Electrical Surge

EN 61000-4-6 – RF Conducted

EN 61000-4-8 – Power Frequency Magnetic Fields

EN 61000-4-11 – Voltage Dips, Short Interrupts and Fluctuations

EN61000-3-2 (Harmonics)

EN61000-3-3 (Voltage Flicker)

EU EMC Directive ((8/9/336/EEC) (CE Compliance)

2.1.4.3 Other Certifications and/or Declarations

GB925 (China/CCC*), CNS13438 (Taiwan/BSMI*), AS/NZ3548 (Australia/C-tick* based on CISPR22)

2.1.5 Catastrophic Failure Protection

Should a component failure occur, the power supply should not exhibit any of the following:

- Flame
- Excessive smoke
- Charred PCB
- Fused PCB conductor
- Startling noise
- Emission of molten material
- Earth ground fault (short circuit to ground or chassis enclosure)

2.2 DC Output

2.2.1 DC Voltage Regulation

The DC output voltages are required to remain within the regulation ranges shown in Table 2, when measured at the load end of the output connectors under all line, load, and environmental conditions specified in Section 5.

Table 2. DC Output Voltage Regulation

Output	Range	Min.	Nom.	Max.	Unit
+12VDC ⁽¹⁾	±5%	+11.40	+12.00	+12.60	Volts
+5VDC	±5%	+4.75	+5.00	+5.25	Volts
+3.3VDC ⁽²⁾	±5%	+3.14	+3.30	+3.47	Volts
-12VDC	±10%	-10.80	-12.00	-13.20	Volts
+5VSB	±5%	+4.75	+5.00	+5.25	Volts

Note: ⁽¹⁾ At +12 VDC peak loading, regulation at the +12 VDC output can go to ± 10%.

⁽²⁾ Voltage tolerance is required at main connector and S-ATA connector (if used).

2.2.2 Remote Sensing

The +3.3 VDC output should have provisions for remote sensing to compensate for excessive cable drops. The default sense should be connected to pin 13 of the main power connector. The power supply should draw no more than 10 mA through the remote sense line to keep DC offset voltages to a minimum.

2.2.3 Typical Power Distribution

DC output power requirements and distributions will vary based on specific system options and implementation.

Significant dependencies include the quantity and types of processors, memory, add-in card slots, and peripheral bays, as well as support for advanced graphics or other features. Table 3 through Table 4 and Figure 1 through Figure 2 shows the power distribution and cross loading tables for power supplies in the range of 180 W to 200W. These are recommendations but *it is ultimately the responsibility of the designer to define a power budget for a given target product and market.*

Table 3. Typical Power Distribution for 180 W Configurations

Output	Minimum Current (amps)	Rated Current (amps)	Peak Current (amps)
+12 VDC	1.0	13.0	14.0
+5 VDC	0.3	8.0	
+3.3 VDC	0.5	5.0	
-12 VDC	0	0.3	
+5 VSB	0	2.0	2.5

Note: Total combined output of 3.3 V and 5 V is ≤ 50 W

Figure 1: Cross Loading Graph for 180W configuration

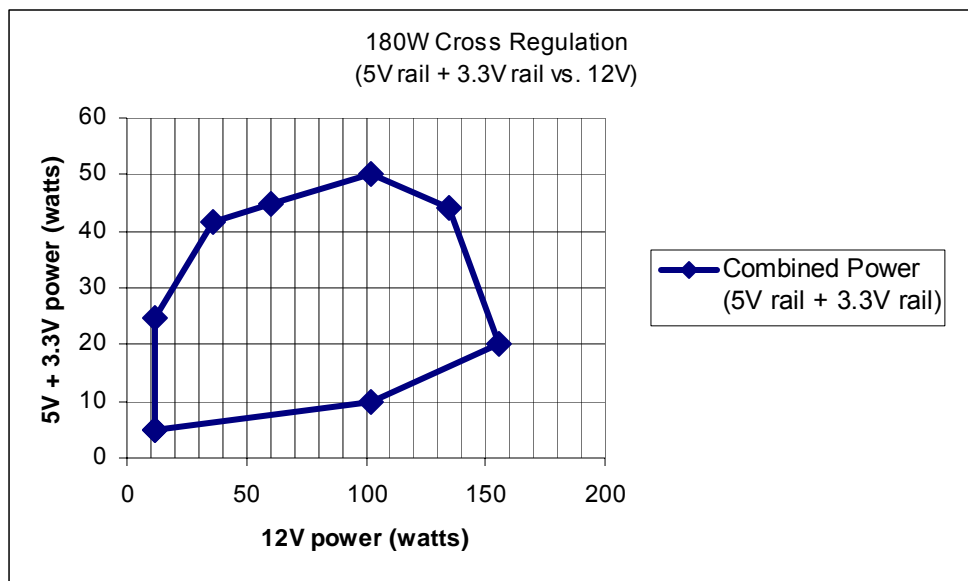
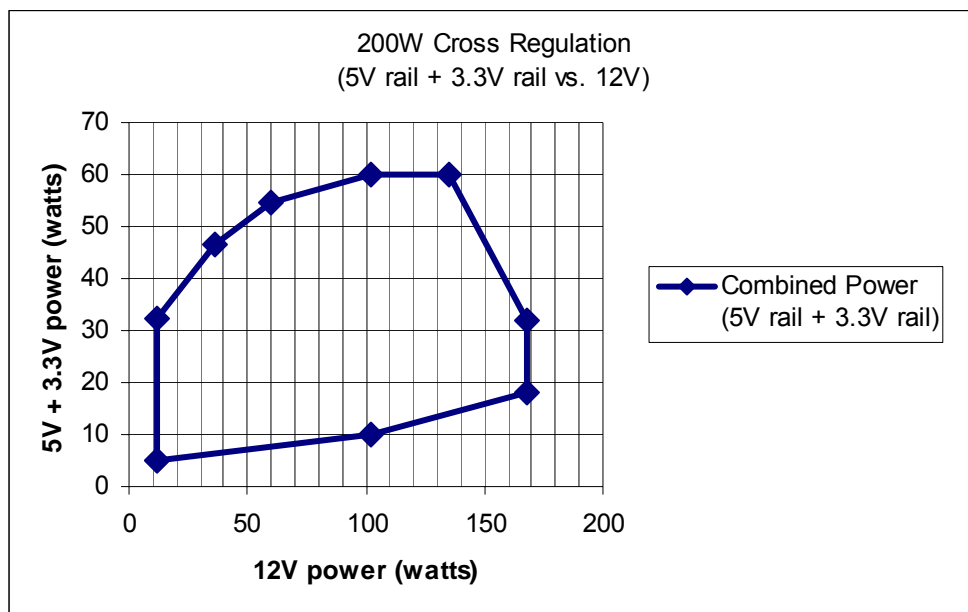

Table 4. Typical Power Distribution for 200 W Configurations

Output	Minimum Current (amps)	Rated Current (amps)	Peak Current (amps)
+12 VDC	1.0	13.5	14.5
+5 VDC	0.3	9.0	
+3.3 VDC	0.5	6.0	
-12 VDC	0	0.3	
+5 VSB	0	2.0	2.5

Note: Total combined output of 3.3 V and 5 V is ≤ 60 W

Figure 2. Cross Loading Graph for 200W Configuration



2.2.4 Power Limit / Hazardous Energy Levels

Under normal or overload conditions, it is required that no output shall continuously provide more than 240 VA under any conditions of load including output short circuit, per the requirement of *UL 1950/CSA 950 / EN 60950/IEC 950* specification.

2.2.5 Efficiency General

The power supply should have a required minimum efficiency as stated in Table 5 and when cost effective provide the recommended efficiency in Table 5. The efficiency of the power supply should be tested at nominal input voltage of 115VAC input and 230VAC input, under the load conditions defined in Table 5, and under the temperature and operating conditions defined in Section 3. The loading condition for testing efficiency shown in Table 5 represents a fully loaded system, a 50% loaded system (typical load), and a 20% loaded (light load) system.

Table 5. Efficiency Vs Load

Loading	Full load	Typical load	Light load
Required: Minimum Efficiency	70%	70%	60%
Recommended: Minimum Efficiency	75%	80%	67%

Table 6. Loading Tables for Efficiency Measurements

180W (loading shown in Amps)					
Loading	+12V	+5V	+3.3V	-12V	+5Vsb
Full	11.0	7.0	4.0	0.2	0.5
Typical	6.0	3.0	3.0	0.1	0.5
Light	2.8	0.3	0.5	0	0.1
200W (loading shown in Amps)					
Loading	+12V	+5V	+3.3V	-12V	+5Vsb
Full	11.5	8.0	6.0	0.2	1.0
Typical	7.0	3.0	4.0	0.1	1.0
Light	3.0	0.4	0.5	0	0.5

2.2.5.1 Energy Star*

The “Energy Star” efficiency requirements of the power supply depend on the intended system configuration. In the low power / sleep state (S1 or S3) the system should consume power in accordance with the values listed in Table 7.

Table 7. Energy Star Input Power Consumption

Maximum Continuous Power Rating of Power Supply	RMS Watts from the AC Line in Sleep/low-Power Mode
$\leq 200\text{ W}$	$\leq 15\text{ W}$
$> 200\text{ W} \leq 300\text{ W}$	$\leq 20\text{ W}$
$> 300\text{ W} \leq 350\text{ W}$	$\leq 25\text{ W}$
$> 350\text{ W} \leq 400\text{ W}$	$\leq 30\text{ W}$
$> 400\text{ W}$	10% of the maximum continuous output rating

Note: To help meet the “Energy Star” system requirements, it is recommended that the power supply have $\geq 50\%$ efficiency at light load and in standby mode.

2.2.5.2 Other Low Power System Requirements

To help meet the Blue Angel* system requirements, RAL-UZ 78, US Presidential executive order 13221, future EPA requirements, and other low Power system demands, it recommended that the +5 VSB standby supply efficiency should be as high as possible. Standby efficiency is measured with the main outputs off (PS_ON# high state). Standby efficiency should be greater than 50% with a load of 100mA.

2.2.6 Output Ripple/Noise

The output ripple/noise requirements listed in

Table 8 should be met throughout the load ranges specified in Section 2.2.3 and under all input voltage conditions as specified in 2.1, Table 1.

Ripple and noise are defined as periodic or random signals over a frequency band of 10 Hz to 20 MHz. Measurements shall be made with an oscilloscope with 20 MHz of bandwidth. Outputs should be bypassed at the connector with a 0.1 μ F ceramic disk capacitor and a 10 μ F electrolytic capacitor to simulate system loading. See Figure 3.

Table 8. DC Output Noise/Ripple

Output	Maximum Ripple and Noise (mVpp)
+12 VDC	120
+5 VDC	50
+3.3 VDC	50
-12 VDC	120
+5 VSB	50

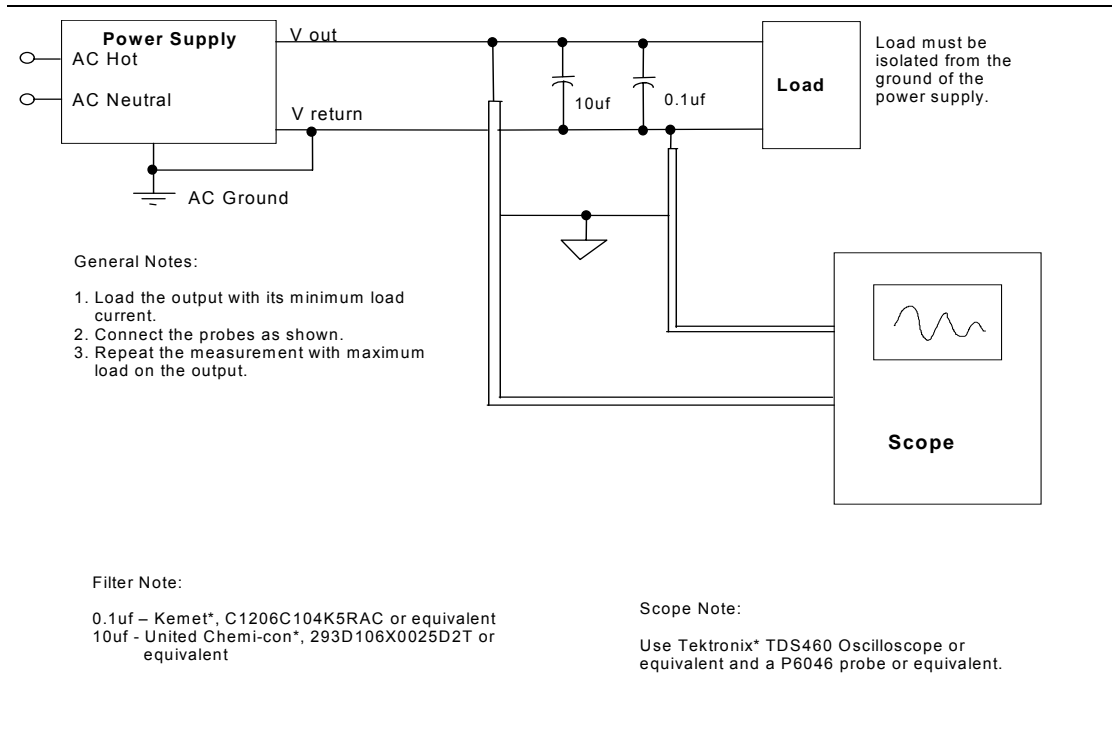

Figure 3. Differential Noise Test Setup

2.2.7 Output Transient Response

Table 9 summarizes the expected output transient step sizes for each output. The transient load slew rate is = 1.0 A/ μ s.

Table 9. DC Output Transient Step Sizes

Output	Maximum Step Size (% of rated output amps)	Maximum Step Size (amps)
+12 VDC	50%	
+5 VDC	30%	
+3.3 VDC	30%	
-12 VDC		0.1 A
+5 VSB		0.5 A

Note: For example, for a rated +5 VDC output of 14 A, the transient step would be $30\% \times 14 \text{ A} = 4.2 \text{ A}$

Output voltages should remain within the regulation limits of Table 2, Section 2.2.1, for instantaneous changes in load as specified in

Table 9 and for the following conditions:

- Simultaneous load steps on the +12 VDC, +5 VDC, and +3.3 VDC outputs (all steps occurring in the same direction)
- Load-changing repetition rate of 50 Hz to 10 kHz
- AC input range per Section 2.1 and capacitive loading per Table 10

2.2.8 Capacitive Load

The power supply should be able to power up and operate with the regulation limits defined in Table 2, Section 2.2.1, with the following capacitances simultaneously present on the DC outputs.

Table 10. Output Capacitive Loads

Output	Capacitive Load (μF)
+12 VDC	3,000
+5 VDC	5,000
+3.3 VDC	3,000
-12 VDC	350
+5 VSB	350

2.2.9 Closed-loop Stability

The power supply is required to be unconditionally stable under all line/load/transient load conditions including capacitive loads specified in Section 2.2.8. A minimum of 45 degrees phase margin and 10 dB gain margin is recommended at both the maximum and minimum loads.

2.2.10 +5 VDC / +3.3 VDC Power Sequencing

The +12 VDC and +5 VDC output levels must be equal to or greater than the +3.3 VDC output at all times during power-up and normal operation. The time between the +12 VDC or +5 VDC output reaching its minimum in-regulation level and +3.3 VDC reaching its minimum in-regulation level must be ≤ 20 ms.

2.2.11 Voltage Hold-up Time

The power supply should maintain output regulations per Section 2.2.1 despite a loss of input power at the low-end nominal range—115 VAC / 57 Hz or 230 VAC / 47 Hz - at maximum continuous output load as applicable for a minimum of 17 ms.

2.3 Timing / Housekeeping / Control

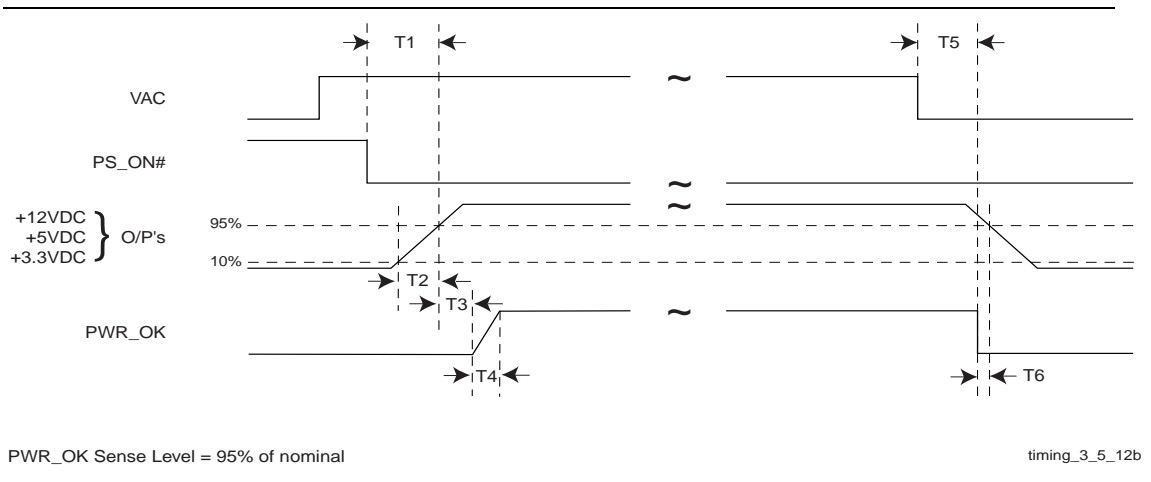

Figure 4. Power Supply Timing

Notes: T1 is defined in Section 2.3.4. , T2 in Section 2.3.5. , T3, T4, T5, and T6 are defined in Table 11.

2.3.1 PWR_OK

PWR_OK is a “power good” signal. This signal should be asserted high by the power supply to indicate that the +12 VDC, +5 VDC, and +3.3 VDC outputs are above the under voltage thresholds listed in Table 2 in Section 2.2.1 and that sufficient mains energy is stored by the converter to guarantee continuous power operation within specification for at least the duration specified in Section 2.2.11, “Voltage Hold-up Time.” Conversely, PWR_OK should be de-asserted to a low state when any of the +12 VDC, +5 VDC, or +3.3 VDC output voltages falls below its under voltage threshold, or when mains power has been removed for a time sufficiently long such that power supply operation cannot be guaranteed beyond the power-down warning time. The electrical and timing characteristics of the PWR_OK signal are given in Table 11 and in Figure 4.

Table 11. PWR_OK Signal Characteristics

Signal Type	+5 V TTL compatible
Logic level low	< 0.4 V while sinking 4 mA
Logic level high	Between 2.4 V and 5 V output while sourcing 200 μ A
High-state output impedance	1 k Ω from output to common
PWR_OK delay	100 ms < T ₃ < 500 ms
PWR_OK rise time	T ₄ \leq 10 ms
AC loss to PWR_OK hold-up time	T ₅ \geq 16 ms
Power-down warning	T ₆ \geq 1 ms

2.3.2 PS_ON#

PS_ON# is an active-low, TTL-compatible signal that allows a motherboard to remotely control the power supply in conjunction with features such as soft on/off, Wake on LAN*, or wake-on-modem. When PS_ON# is pulled to TTL low, the power supply should turn on the four main DC output rails: +12 VDC, +5 VDC, +3.3 VDC, and -12 VDC. When PS_ON# is pulled to TTL high or open-circuited, the DC output rails should not deliver current and should be held at zero potential with respect to ground. PS_ON# has no effect on the +5 VSB output, which is always enabled whenever the AC power is present. Table 12 lists PS_ON# signal characteristics.

The power supply shall provide an internal pull-up to TTL high. The power supply shall also provide de-bounce circuitry on PS_ON# to prevent it from oscillating on/off at startup when activated by a mechanical switch. The DC output enable circuitry must be SELV-compliant.

The power supply shall not latch into a shutdown state when PS_ON# is driven active by pulses between 10ms to 100ms during the decay of the power rails.

Table 12. PS_ON# Signal Characteristics

Parameter	Minimum	Maximum
V _{IL} , Input Low Voltage	0.0 V	0.8 V
I _{IL} , Input Low Current (V _{in} = 0.4 V)		-1.6 mA
V _{IH} , Input High Voltage (I _{in} = -200 μ A)	2.0 V	
V _{IH} open circuit, I _{in} = 0		5.25 V

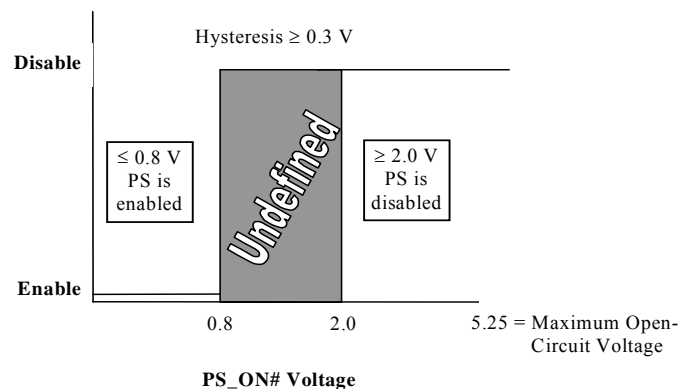

Figure 5. PS_ON# Signal Characteristics

2.3.3 +5 VSB

+5 VSB is a standby supply output that is active whenever the AC power is present. This output provides a power source for circuits that must remain operational when

the five main DC output rails are in a disabled state. Example uses include soft power control, Wake on LAN, wake-on-modem, intrusion detection, or suspend state activities.

The +5 VSB output should be capable of delivering a minimum of 2.0 A. at +5 V \pm 5% to external circuits. The power supply is required to provide the required power during a "wake up" event. If an external USB device generates the event, there may be peak currents as high as 2.5 A., lasting no more than 500 ms.

Over current protection is required on the +5 VSB output regardless of the output current rating. This ensures the power supply will not be damaged if external circuits draw more current than the supply can provide.

2.3.4 Power-on Time

The power-on time is defined as the time from when PS_ON# is pulled low to when the +12 VDC, +5 VDC, and +3.3 VDC outputs are within the regulation ranges specified in Section 2.2.1. The power-on time shall be less than 500 ms ($T_1 < 500$ ms).

+5 VSB shall have a power-on time of two seconds *maximum* after application of valid AC voltages.

2.3.5 Rise Time

The output voltages shall rise from $\leq 10\%$ of nominal to within the regulation ranges specified in Section 2.2.1 within 0.2 ms to 20 ms ($0.2 \text{ ms} \leq T_2 \leq 20 \text{ ms}$).

There must be a smooth and continuous ramp of each DC output voltage from 10% to 90% of its final set point within the regulation band, while loaded as specified in 2.2.3 .

The smooth turn-on requires that, during the 10% to 90% portion of the rise time, the slope of the turn-on waveform must be positive and have a value of between 0 V/ms and $[V_{\text{out, nominal}} / 0.1]$ V/ms. Also, for any 5 ms segment of the 10% to 90% rise time waveform, a straight line drawn between the end points of the waveform segment must have a slope $\geq [V_{\text{out, nominal}} / 20]$ V/ms.

2.3.6 Overshoot at Turn-on / Turn-off

The output voltage overshoot upon the application or removal of the input voltage, or the assertion/de-assertion of PS_ON#, under the conditions specified in Section 2.2, shall be less than 10% above the nominal voltage. No voltage of opposite polarity shall be present on any output during turn-on or turn-off.

2.3.7 Reset after Shutdown

If the power supply latches into a shutdown state because of a fault condition on its outputs, the power supply shall return to normal operation only after the fault has

been removed and the PS_ON# has been cycled OFF/ON with a minimum OFF time of one second.

2.3.8 +5 VSB at AC Power-down

After AC power is removed, the +5 VSB standby voltage output should remain at its steady state value for the minimum hold-up time specified in Section 2.2.11 until the output begins to decrease in voltage. The decrease shall be monotonic in nature, dropping to 0.0 V. There shall be no other disturbances of this voltage at or following removal of AC power.

2.4 Output Protection

2.4.1 Over Voltage Protection

The over voltage sense circuitry and reference shall reside in packages that are separate and distinct from the regulator control circuitry and reference. No single point fault shall be able to cause a sustained over voltage condition on any or all outputs. The supply shall provide latch-mode over voltage protection as defined in Table 13.

Table 13. Over Voltage Protection

Output	Minimum	Nominal	Maximum	Unit
+12 VDC	13.4	15.0	15.6	Volts
+5 VDC	5.74	6.3	7.0	Volts
+3.3 VDC	3.76	4.2	4.3	Volts

2.4.2 Short-circuit Protection

An output short circuit is defined as any output impedance of less than 0.1 ohms. The power supply shall shut down and latch off for shorting the +3.3 VDC, +5 VDC, or +12 VDC rails to return or any other rail. Shorts between main output rails and +5 VSB shall not cause any damage to the power supply. The power supply shall either shut down and latch off or fold back for shorting the negative rails. +5 VSB must be capable of being shorted indefinitely, but when the short is removed, the power supply shall recover automatically or by cycling PS_ON#. The power supply shall be capable of withstanding a continuous short circuit to the output without damage or overstress to the unit (for example, to components, PCB traces, and connectors) under the input conditions specified in Section 2.1

2.4.3 No-load Operation

No damage or hazardous condition should occur with all the DC output connectors disconnected from the load. The power supply may latch into the shutdown state.

2.4.4 Over Current Protection

Overload currents applied to each tested output rail cause the output to trip before reaching or exceeding 240 VA. For testing purposes, the overloaded currents should be ramped at a minimum rate of 10 A/s starting from full load.

2.4.5 Over-temperature Protection

As an option, it is recommended that the power supply may include an over-temperature protection sensor, which can trip and shut down the power supply at a preset temperature point. Such an overheated condition is typically the result of internal current overloading or a cooling fan failure. If the protection circuit is non-latching, then it should have hysteresis built in to avoid intermittent tripping.

2.4.6 Output Bypass

The output return may be connected to the power supply chassis, and will be connected to the system chassis by the system components.

3 Mechanical

3.1 Labeling /Marking

The following is a non-inclusive list of suggested markings for each power supply unit. Product regulation stipulations for sale into various geographies may impose additional labeling requirements.

Manufacturer information: manufacturer's name, part number and lot date code, etc., in human-readable text and/or bar code formats

Nominal AC input operating voltages (see Table 1) and current rating certified by all applicable safety agencies

DC output voltages and current ratings

Access warning text (“Do not remove this cover. Trained service personnel only. No user serviceable components inside.”) must be in English, German, Spanish, French, Chinese, and Japanese with universal warning markings

3.2 Physical Dimensions

The power supply shall be enclosed and meet the physical outline shown in Figure 6, as applicable. Mechanical details are shown in Figure 7. Details on the power supply slot feature are shown in Figure 8. The recommended chassis slot feature details are shown in Figure 9.

LFX12V Power Supply Design Guide

Lowprofile Form Factor with 12-Volt Connector

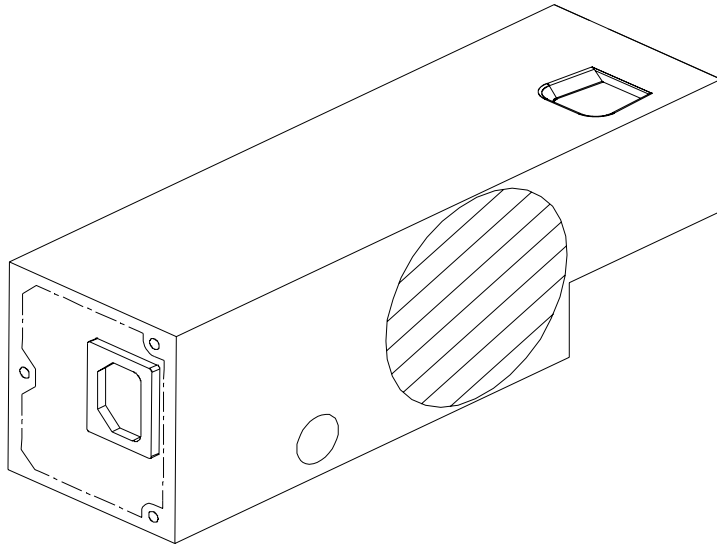

Figure 6. Mechanical Outline

LFX12V Power Supply Design Guide

Lowprofile Form Factor with 12-Volt Connector

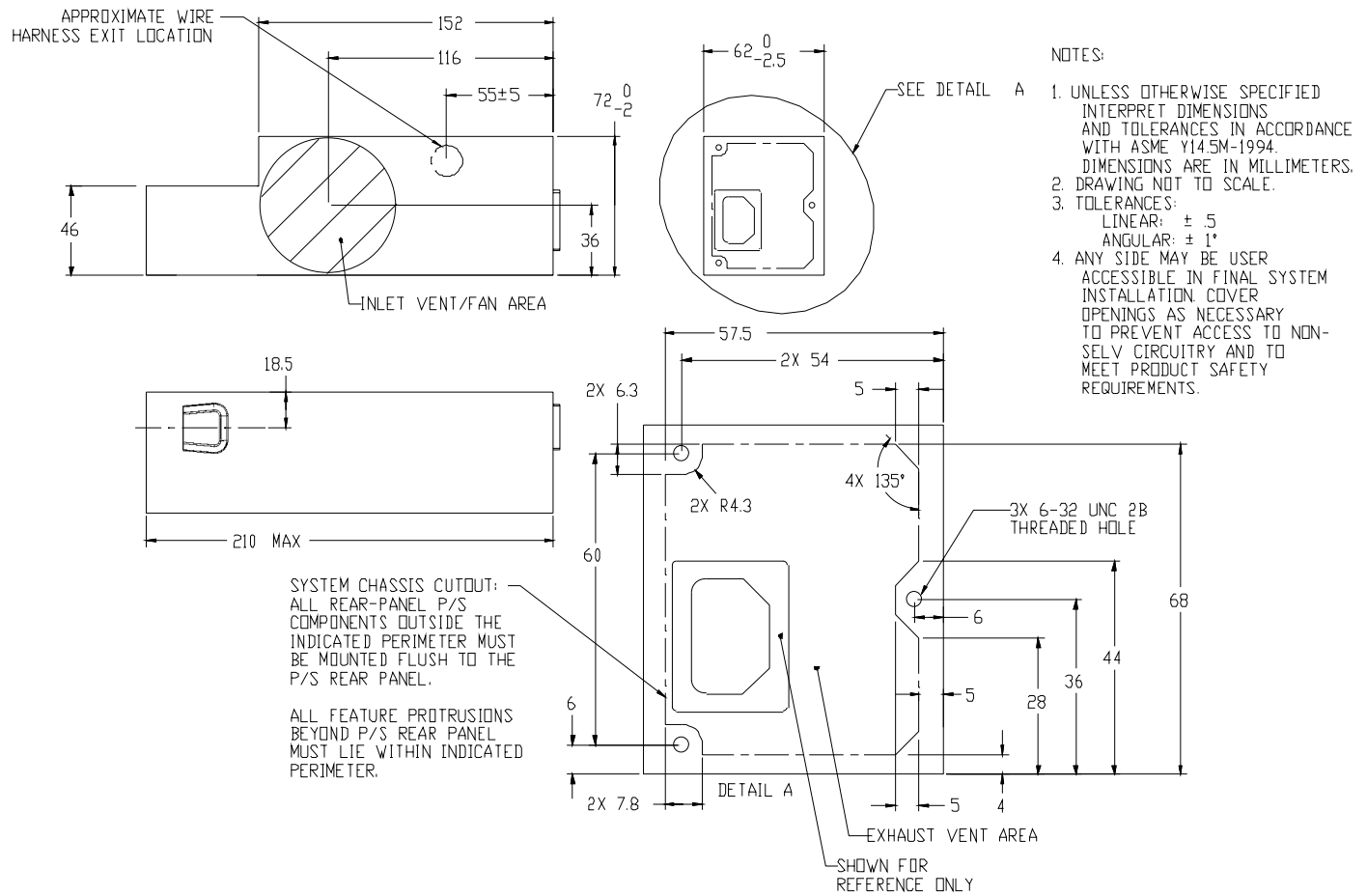

Figure 7. Mechanical Details

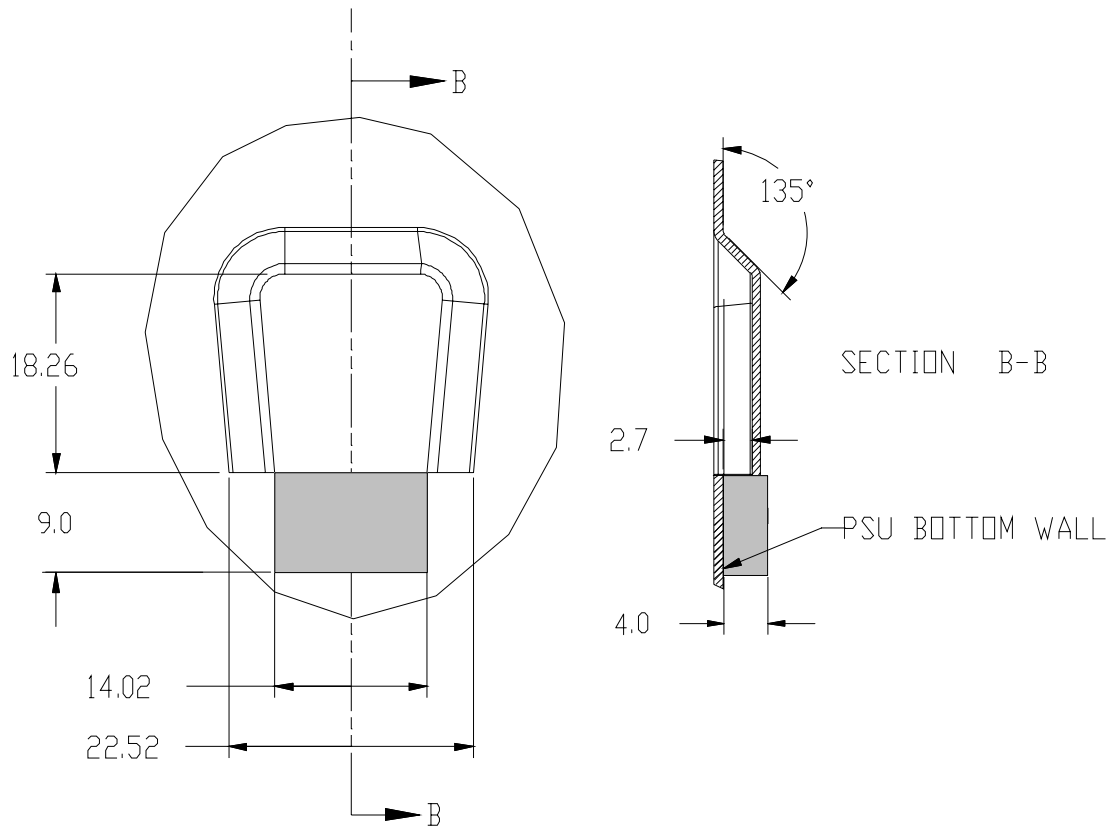

Figure 8. PSU Slot Feature Detail

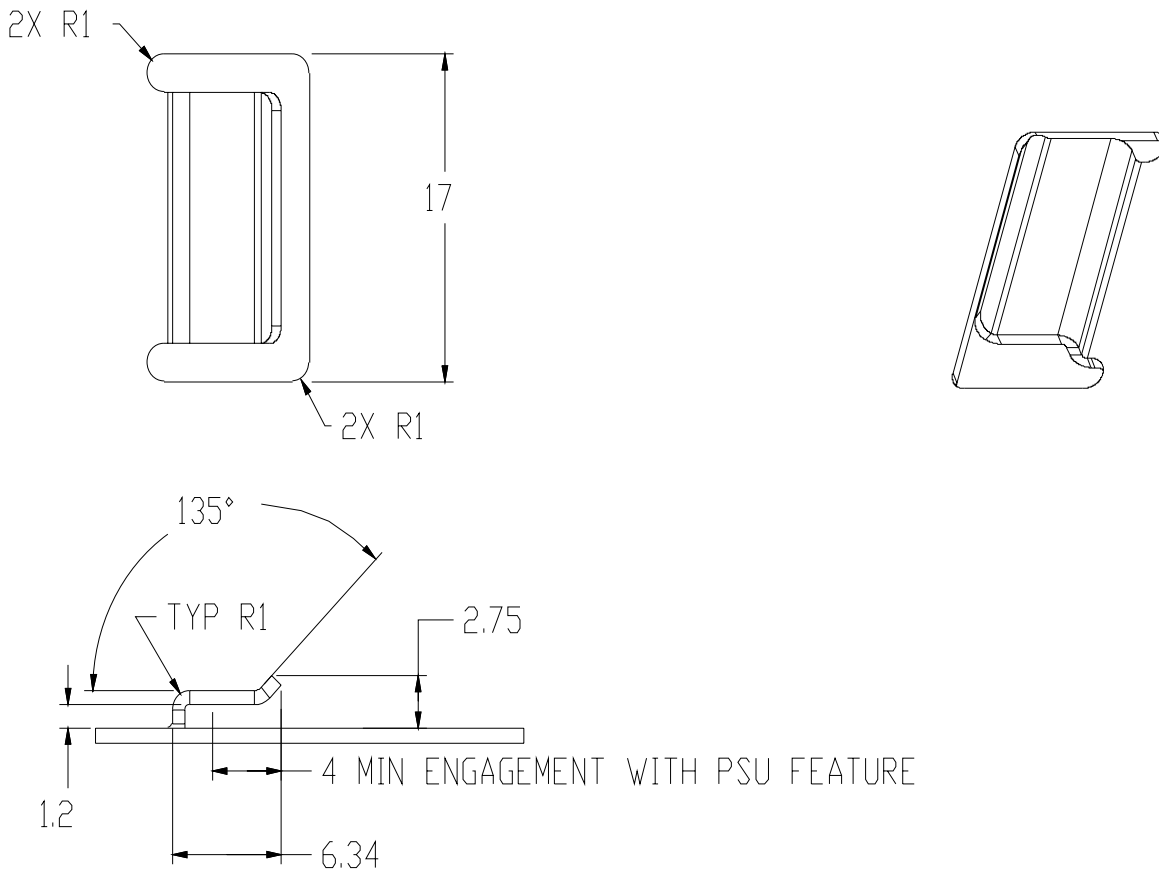

Figure 9. Recommended Chassis Tab Feature

3.3 AC Connector

The AC input receptacle should be an IEC 320 type or equivalent. In lieu of a dedicated switch, the IEC 320 receptacle may be considered the mains disconnect.

3.4 DC Connectors

Figure 10 shows pin outs and profiles for typical power supply DC harness connectors.

UL Listed or recognized component appliance wiring material rated min 85 °C, 300 VDC shall be used for all output wiring.

There are no specific requirements for output wire harness lengths, as these are largely a function of the intended end-use chassis, motherboard, and peripherals.

Ideally, wires should be short to minimize electrical/airflow impedance and simplify manufacturing, yet they should be long enough to make all necessary connections without any wire tension (which can cause disconnections during shipping and handling). Recommended minimum harness lengths for general-use power supplies is 150 mm for all wire harnesses. Measurements are made from the exit port of the power supply case to the wire side of the first connector on the harness.

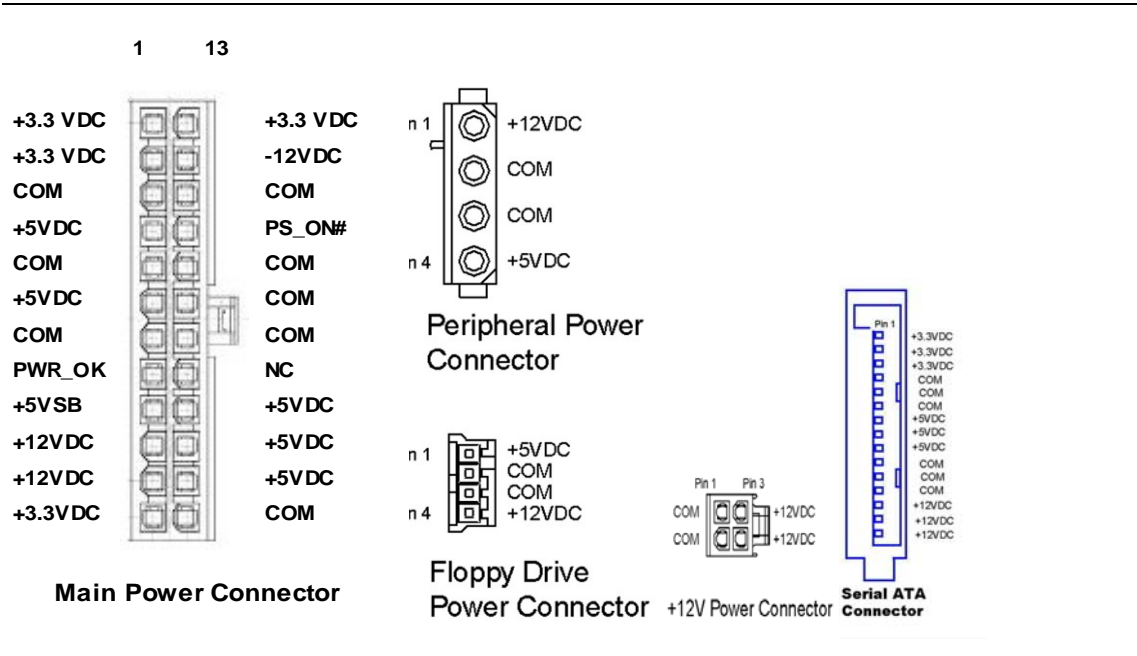

Figure 10. Connectors (Pin-side view, not to scale)

3.4.1 Main Power Connector

Connector: MOLEX* *Housing: 24 Pin Molex Mini-Fit Jr. PN# 39-01-2240 or equivalent.*

(Mating motherboard connector is Molex 44206-0007 or equivalent)

18 AWG is suggested for all wires except for the +3.3 V supply and sense return wires combined into pin 13 (22 AWG).

Pin	Signal	Color	Pin	Signal	Color
1	+3.3 VDC	Orange	13 [13]	+3.3 VDC [+3.3 V default sense]	Orange [Brown]
2	+3.3 VDC	Orange	14	-12 VDC	Blue
3	COM	Black	15	COM	Black
4	+5 VDC	Red	16	PS_ON#	Green
5	COM	Black	17	COM	Black
6	+5 VDC	Red	18	COM	Black
7	COM	Black	19	COM	Black
8	PWR_OK	Gray	20	Reserved	NC
9	+5 VSB	Purple	21	+5 VDC	Red
10	+12 VDC	Yellow	22	+5 VDC	Red
11	+12 VDC	Yellow	23	+5 VDC	Red
12	+3.3 VDC	Orange	24	COM	Black

3.4.2 Peripheral Connector(s)

Connector: AMP* 1-480424-0 or MOLEX 8981-04P or equivalent.

Contacts: AMP 61314-1 or equivalent.

Pin	Signal	18 AWG Wire
1	+12 VDC	Yellow
2	COM	Black
3	COM	Black
4	+5 VDC	Red

3.4.3 Floppy Drive Connector

Connector: AMP 171822-4 or equivalent

Pin	Signal	20 AWG Wire
1	+5 VDC	Red
2	COM	Black
3	COM	Black
4	+12 VDC	Yellow

+12 V Power Connector

Connector: MOLEX 39-01-2040 or equivalent (Mating motherboard connector is Molex 39-29-9042 or equivalent)

Pin	Signal	18 AWG Wire	Pin	Signal	18 AWG Wire
1	COM	Black	3	+12 VDC	Yellow
2	COM	Black	4	+12 VDC	Yellow

3.4.4 Serial ATA Power Connector

This is a required connector for systems with Serial ATA* devices.

The detailed requirements for the Serial ATA Power Connector can be found in the “Serial ATA: High Speed Serialized AT Attachment” specification, Section 6.3 “Cables and connector specification”. <http://www.serialata.org/>

Note: connector pin numbers and wire numbers are not 1:1. Carefully check to confirm the correct arrangement.

Assembly: MOLEX 88751 or equivalent.

Wire	Signal	18 AWG Wire
5	+3.3 VDC	Orange
4	COM	Black
3	+5 VDC	Red
2	COM	Black
1	+12 VDC	Yellow

Molex Housing #675820000 or equivalent
Molex Terminal #675810000 or equivalent

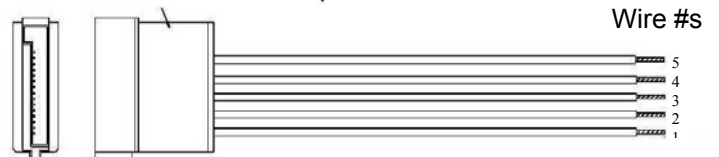

Figure 11. Serial ATA Connector

4 Thermal Requirements

4.1 Fan and Venting

The fan will draw air from the system enclosure and exhaust the air through a grill located on the back panel.

The intake and exhaust grills of the power supply shall remain suitably free of obstruction so as not to hinder airflow. The opening must be sufficiently protected to meet the safety requirements of Section 6. It is recommended that a flush-mount wire fan grill be used to maximize airflow and minimize acoustic noise.

4.2 Airflow and Acoustics

It is recommended but not required that the power supply be designed with an appropriate fan, internal impedance, and fan speed control circuitry capable of meeting the airflow and acoustic recommendations listed in Table 14.

Pure Tones: The power supply assembly shall not produce any prominent discrete tone determined according to ISO 7779, Annex D.

Table 14. Airflow and Acoustic Recommendations

T_{PSU_INLET}	DC output load	Airflow ⁽¹⁾	Declared sound power, LwAd ⁽²⁾
46°C, sea level	Test Condition 1 See: <ul style="list-style-type: none"> Table 15 Table 16 for loadings	≥ 2.0 CFM	≤ 3.34 BA
50°C, sea level	Test Condition 2 See: <ul style="list-style-type: none"> Table 15 Table 16 for loadings	≥ 6.0 CFM	≤ 5.7 BA

Notes:

- (1) Airflow in cubic feet per minute (CFM) through the power supply to be measured per AMCA* Standard 210 (see Figure 12).
- (2) The declared sound power level shall be measured according to ISO 7779 for the power supply unit alone (i.e. not in a system chassis) and reported according to ISO 9296.

Table 15. Loading for Acoustic Test for 180 Watts

Loading condition	+12V (A)	+5V (A)	+3.3V (A)	-12V (A)	+5Vsb (A)	Total Power (W)
Test Condition 1	5.5	3.0	2.0	0.1	1.0	93.8
Test Condition 2	11.0	5.5	4.0	0.2	1.0	180

Table 16. Loading for Acoustic Test for 200 Watts

Loading condition	+12V (A)	+5V (A)	+3.3V (A)	-12V (A)	+5Vsb (A)	Total Power (W)
Test Condition 1	6.0	5.5	3.5	0.1	0.8	116
Test Condition 2	11.5	7.6	5.0	0.2	1.0	200

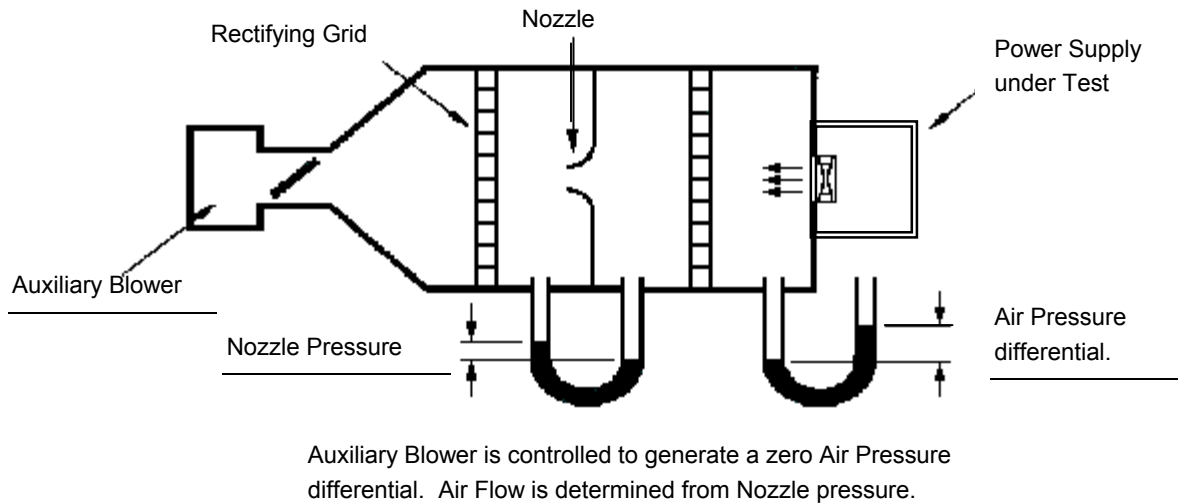

Figure 12. AMCA* Standard 210

4.3 Airflow / Fan

The designer's choice of a power supply cooling solution depends in part on the targeted end-use system application(s). At a minimum, the power supply design must ensure its own reliable and safe operation.

Fan location/direction: In general, exhausting air from the system chassis enclosure via a power supply fan is the preferred, most common, and most widely applicable system-level airflow solution. The location of the fan can have a large effect on how efficiently this air is exhausted. The location of the fan shown in Figure 6 allows the fan to be located in an effective manner to can aid in the evacuation of heated air and helps keep the total system cooler.

Fan size/speed: The power supply can support up to a 70 mm axial fan. It is recommended that a thermally sensitive fan speed control circuit be used to balance system-level thermal and acoustic performance. The circuit typically senses the temperature of the secondary heat sink and/or incoming ambient air and adjusts the fan speed as necessary to keep power supply and system component temperatures within specifications. Both the power supply and system designers should be aware of the dependencies of the power supply and system temperatures on the control circuit response curve and fan size and should specify them carefully.

The power supply fan should be turned off when PS_ON# is de-asserted (high). In this state, any remaining active power supply circuitry must rely only on passive convection for cooling.

Venting: In general, more venting in a power supply case yields reduced airflow impedance and improved cooling performance. Intake and exhaust vents should be as large, open, and unobstructed as possible so as not to impede airflow or generate excessive acoustic noise. In particular, avoid placing objects within 0.5 inches of the intake or exhaust of the fan itself. A raised wire fan grill is recommended instead of a stamped metal vent for improved airflow and reduced acoustic noise for the intake vent.

Considerations to the previous venting guidelines are:

- Openings must be sufficiently designed to meet the safety requirements described in Section 5.
- Larger openings yield decreased EMI-shielding performance. The design should always be tested per requirements outlined in Section 2.1.4.2.

NOTE:

Venting in inappropriate locations can detrimentally allow airflow to bypass those areas where it is needed.

5 Environmental

The following subsections define recommended environmental specifications and test parameters, based on the typical conditions the power supply unit may be subjected to during operation or shipment.

5.1 Temperature

Operating ambient: +10 °C to +50 °C (At full load, with a maximum temperature rate of change of 5 °C/10 minutes, but no more than 10 °C/hr.)

Non-operating ambient: -40 °C to +70 °C (Maximum temperature rate of change of 20 °C/hr.)

5.2 Thermal Shock (Shipping)

Non-operating: -40 °C to +70 °C

15 °C/min \leq dT/dt \leq 30 °C/min. Tested for 50 cycles; Duration of exposure to temperature extremes for each half cycle shall be 30 minutes.

5.3 Relative Humidity

Operating: To 85% relative humidity (non-condensing)

Non-operating: To 95% relative humidity (non-condensing)

Note: 95% RH is achieved with a dry bulb temperature of 55 °C and a wet bulb temperature of 54 °C.

5.4 Altitude Requirement

Operating: To 10,000 ft

Non-operating: To 50,000 ft

5.5 Mechanical Shock

Non-operating: 50 g, trapezoidal input; velocity change \geq 170 in/s

Three drops on each of six faces are applied to each sample.

5.6 Random Vibration

Non-operating: 0.01 g²/Hz at 5 Hz, sloping to 0.02 g²/Hz at 20 Hz, and maintaining 0.02 g²/Hz from 20 Hz to 500 Hz. The area under the PSD curve is 3.13 gRMS. The duration shall be 10 minutes per axis for all three axes on all samples.

5.7 Acoustics

Sound Power: See 4.2.

5.8 Ecological Requirements

The following materials must not be used during design and/or manufacturing of this product:

Cadmium shall not be used in painting or plating.

Quaternary salt and PCB electrolytic capacitors shall not be used.

CFC's or HFC's shall not be used in the design or manufacturing process.

Mercury shall not be used.

6 Safety

The following subsections outline sample product regulations requirements for a typical power supply. Actual requirements will depend on the design, product end use, target geography, and other variables. Consult your company's Product Safety and Regulations department for more details.

6.1 North America

The power supply must be certified by an NRTL (Nationally Recognized Testing Laboratory) for use in the USA and Canada under the following conditions:

The supply must be Recognized for use in Information Technology Equipment including Electrical Business Equipment per *UL 1950 / CAN/CSA C22.2 No. 950-95*, renamed *UL 60950, 3rd edition*, without D3 deviations. The certification must include external enclosure testing for the AC receptacle side of the power supply (see Appendices A, B, C, and D).

The supply must have a full complement of tests conducted as part of the certification, such as input current, leakage current, hi-pot, temperature, energy discharge test, transformer output characterization test (open-circuit voltage, short-circuit current, and maximum VA output), and abnormal testing (to include stalled-fan tests and voltage-select-switch mismatch).

The enclosure must meet fire enclosure mechanical test requirements per clauses 2.9.1 and 4.2 of the above-mentioned standard.

100% production HiPot testing must be included and marked as such on the power supply enclosure.

There must not be unusual or difficult conditions of acceptability such as mandatory additional cooling or power de-rating. The insulation system shall not have temperatures exceeding their rating when tested in the end product.

The certification mark shall be marked on each power supply.

The power supply must be evaluated for operator-accessible secondary outputs (reinforced insulation) that meet the requirements for SELV and do not exceed 240 VA under any condition of loading.

The proper polarity between the AC input receptacle and any printed wiring boards connections must be maintained (that is, brown=line, blue=neutral, and green=earth/chassis).

Failure of any single component in the fan-speed control circuit shall not cause the internal component temperatures to exceed the abnormal fault condition temperatures per the *IEC 60950 Specification*.

6.2 International

The vendor must provide a complete CB* certificate and test report to *IEC 60950:1991, 2nd edition + A1, A2, A3, and A4*. The CB report must include ALL CB member country national deviations. The CB report must include an evaluation summary to *EN 60950:1992, + A1, A2, A3, A4 and Nordic deviations EMKO-TSE* (74-SEC) 207/94*. All evaluations and certifications must be for reinforced insulation between primary and secondary circuits.

7 System Cooling Considerations

The power supply fan location allows the system designer to utilize the airflow to help cool critical components such as the processor and chipset. Please note that the fan pulls air from the system, instead of blowing hot air in, so components must be placed such that airflow is directed across critical components. Cables, etc must not impede airflow.

For more information on system thermal design, please refer to <http://www.formfactors.org/>.

8 Reliability

The de-rating process promotes quality and high reliability. All electronic components should be designed with conservative device deratings for use in commercial and industrial environments.

9 Applicable Documents

The following documents support this design guide as additional reference material.

Document Title	Description
<i>AB13-94-146</i>	European Association of Consumer Electronics Manufacturers (EACEM*) Hazardous Substance List / Certification
<i>ANSI* C62.41-1991</i>	IEEE* Recommended Practice on Surge Voltages in Low-Voltage AC Circuits
<i>ANSI C62.45-1992</i>	IEEE Guide on Surge Testing for Equipment Connected to Low-Voltage AC Power Circuits
<i>CSA C22.2 No.234, Level 3</i>	Safety of Component Power Supplies (Intended for use with Electronic Data Processing Equipment and Office Machines)
<i>CAN/CSA C22.2 No.950-95, 3rd edition</i>	Safety of Information Technology Equipment Including Electrical Business Equipment
<i>UL 1950, 3rd edition, without D3 Deviation</i>	Safety of Information Technology Equipment Including Electrical Business Equipment
<i>IEC 60950, 2nd ed. 1991: plus A1, A2, A3, A4</i>	Safety of Information Technology Equipment Including Business Equipment
<i>EN 60950, 2nd ed. 1992: plus A1, A2, A3, A4</i>	Safety of Information Technology Equipment Including Business Equipment
<i>EMKO-TSE (74-SEC) 207/94</i>	Nordic national requirement in addition to EN 60950
<i>CISPR 22:1997 3rd edition EN 55022:1998</i>	Limits and Methods of Measurements of Radio Interference Characteristics of Information Technology Equipment, Class B
<i>ANSI C63.4 – 1992</i>	American National Standard for Methods of Measurement of Radio-Noise Emissions from Low-Voltage Electrical and Electronic Equipment in the Range of 9 kHz to 40 GHz for EMI testing

LFX12V Power Supply Design Guide

Lowprofile Form Factor with 12-Volt Connector

Document Title	Description
AS/NZS 3548 (Class B)	Australian Communications Authority, Standard for Electromagnetic Compatibility* (AU & NZ)
CNS* 13438	Limits and methods of measurement of radio disturbance characteristics of Information Technology Equipment (Taiwan & China)
EN 55024:1998	Information technology equipment—Immunity characteristics—Limits and methods of measurement
CISPR 24: 1997	Information technology equipment—Immunity characteristics—Limits and methods of measurement
EN 61000-3-2	Electromagnetic compatibility (EMC)—Part 3: Limits—Section 2: Limits for harmonic current emissions, Class D
IEC 61000-4-	Electromagnetic compatibility (EMC) for industrial-process measurement and control equipment—Part 4: Testing and measurement techniques Section -2: Electrostatic discharge Section -3: Radiated, radio-frequency, electromagnetic field Section -4: Electrical fast transient / burst Section -5: Surge Section -6: Conducted disturbances, induced by radio-frequency fields Section -8: Power frequency magnetic fields Section -11: Voltage dips, short interruptions, and voltage variations
Japan Electric Association*	Guidelines for the Suppression of Harmonics in Appliances and General Use Equipment
IEC Publication 417	International Graphic Symbol Standard
ISO Standard 7000	Graphic Symbols for Use on Equipment
CFR 47, Part 15, Subpart B	FCC Regulations pertaining to unintentional radiators (USA)
ICES*-003 (Class B)	Interference-Causing Equipment Standard, Digital Apparatus (Canada)
VCCI* V-3/99.05 (Class B)	Implementation Regulations for Voluntary Control of Radio Interference by Data processing Equipment and Electronic Office Machines (Japan)