

EPS12V

Power Supply Design Guide

***A Server System Infrastructure (SSI) Specification
For Entry Chassis Power Supplies***

Version 1.6

Disclaimer:

THIS SPECIFICATION IS PROVIDED "AS IS" WITH NO WARRANTIES WHATSOEVER, INCLUDING ANY WARRANTY OF MERCHANTABILITY, NONINFRINGEMENT, FITNESS FOR ANY PARTICULAR PURPOSE, OR ANY WARRANTY OTHERWISE ARISING OUT OF ANY PROPOSAL, SPECIFICATION OR SAMPLE. WITHOUT LIMITATION, THE PROMOTERS (Intel Corporation, NEC Corporation, Dell Computer Corporation, Data General a division of EMC Corporation, Compaq Computer Corporation, Silicon Graphics Inc., and International Business Machines Corporation) DISCLAIM ALL LIABILITY FOR COST OF PROCUREMENT OF SUBSTITUTE GOODS OR SERVICES, LOST PROFITS, LOSS OF USE, LOSS OF DATA OR ANY INCIDENTAL, CONSEQUENTIAL, DIRECT, INDIRECT, OR SPECIAL DAMAGES, WHETHER UNDER CONTRACT, TORT, WARRANTY OR OTHERWISE, ARISING IN ANY WAY OUT OF USE OR RELIANCE UPON THIS SPECIFICATION OR ANY INFORMATION HEREIN.

The Promoters disclaim all liability, including liability for infringement of any proprietary rights, relating to use of information in this specification. No license, express or implied, by estoppel or otherwise, to any intellectual property rights is granted herein.

This specification and the information herein is the confidential and trade secret information of the Promoters. Use, reproduction and disclosure of this specification and the information herein is subject to the terms of the S.S.I. Specification Adopter's Agreement.

Copyright © Intel Corporation, NEC Corporation, Dell Computer Corporation, Data General a division of EMC Corporation, Compaq Computer Corporation, Silicon Graphics Inc., International Business Machines Corporation, 2000.

Contents

1	Purpose	6
2	Conceptual Overview	6
3	Definitions/Terms/Acronyms	6
4	Mechanical Overview	8
4.1	Airflow Requirements	9
4.2	Temperature Requirements	9
5	AC Input Requirements	10
5.1	AC Inlet Connector	10
5.2	AC Input Voltage Specification	10
5.3	Input Under Voltage	11
5.4	Efficiency	11
5.5	AC Line Dropout	11
5.6	AC Line Fuse	11
5.7	AC Inrush	12
5.8	AC Line Transient Specification	12
5.9	AC Line Fast Transient Specification	13
6	DC Output Specification	13
6.1	Output Connectors	13
6.1.1	Required Baseboard power connector	13
6.1.2	Required Processor Power Connector	14
6.1.3	Required Peripheral Power Connectors	14
6.1.4	Floppy Power Connector	15
6.1.5	Optional Server Signal Connector	15
6.1.6	Optional Workstation Power Connector	16
6.2	Grounding	16
6.3	Remote Sense	16
6.4	Output Power/Currents	17
6.4.1	Standby Outputs	18
6.5	Voltage Regulation	18
6.6	Dynamic Loading	19
6.7	Capacitive Loading	20
6.8	Ripple / Noise	20
6.9	Timing Requirements	20
7	Protection Circuits	24
7.1	Current Limit	24
7.2	240VA Protection	24
7.3	Over Voltage Protection	25
7.4	Over Temperature Protection	25
8	Control and Indicator Functions	26
8.1	PSO#	26
8.2	PWOK (Power OK)	27
8.3	Field Replacement Unit (FRU) Signals	28
8.3.1	FRU Data	28

8.3.2	FRU Data Format	28
9	MTBF.....	30
10	Agency Requirements	30

Figures

Figure 1:	Enclosure Drawing.....	8
Figure 2:	Output Voltage Timing	21
Figure 3:	Turn On/Off Timing (Single Power Supply)	23
Figure 4:	PSON# Signal Characteristics.....	26

Tables

Table 1:	Thermal Requirements.....	9
Table 2:	AC Input Rating.....	10
Table 3:	AC Line Sag Transient Performance	12
Table 4:	AC Line Surge Transient Performance	12
Table 5:	P1 Baseboard Power Connector	13
Table 6:	Processor Power Connector	14
Table 7:	Peripheral Power Connectors	14
Table 8:	P8 Floppy Power Connector	15
Table 9:	Server Signal Connector	15
Table 10:	Workstation Power Connector	16
Table 11:	550 W Load Ratings.....	17
Table 12:	450 W Load Ratings.....	18
Table 13:	Voltage Regulation Limits	19
Table 14:	Optional +5V Regulation Limits	19
Table 15:	Transient Load Requirements.....	19
Table 16:	Capacitive Loading Conditions	20
Table 17:	Ripple and Noise.....	20
Table 18:	Output Voltage Timing	21
Table 19:	Turn On/Off Timing	22
Table 20:	Over Current Protection	24
Table 21:	Over Current Protection	25
Table 22:	Over Voltage Limits.....	25
Table 23:	PSON# Signal Characteristic.....	26
Table 24:	PWOK Signal Characteristics	27
Table 25:	FRU Device Information.....	28
Table 26:	FRU Device Product Information Area.....	28
Table 27:	MultiRecord information Area	29

1 Purpose

This specification defines a non-redundant power supply that supports entry server computer systems. This specification defines a 450 W and a 550 W power supply with 6 outputs; 3.3 V, 5 V, 12V1, 12V2, 12V3, -12 V, and 5 VSB. The form factor is stretch PS/2, with connector/cable assemblies required for the motherboard power, remote sensing and control functions, and peripheral power. Because of its connector leads, the entry-level power supply is not intended to be a hot swap type of power supply. The cooling fan should meet the acoustical requirements for the system, while providing system cooling.

The parameters of this supply are defined in this specification for open industry use.

2 Conceptual Overview

In the Entry server market, the bulk power system must source power on several output rails.

These rails are typically as follows:

- +3.3 V
- +5 V
- +12 V
- -12 V
- +5 V standby

NOTE

Local DC-DC converters shall be utilized for processor power, and will ideally convert power from the +12 V rail, however, they may also convert power from other rails.

3 Definitions/Terms/Acronyms

Required	The status given to items within this design guide, which are required to meet SSI guidelines and a large majority of system applications.
Recommended	The status given to items within this design guide which are not required to meet SSI guidelines, however, are required by many system applications.
Optional	The status given to items within this design guide, which are not required to meet SSI guidelines, however, some system applications may optionally use these features.
Autoranging	A power supply that automatically senses and adjusts itself to the proper input voltage range (110 VAC or 220 VAC). No manual switches or manual adjustments are needed.
CFM	Cubic Feet per Minute (airflow).
Dropout	A condition that allows the line voltage input to the power supply to drop to below the minimum operating voltage.

Latch Off	A power supply, after detecting a fault condition, shuts itself off. Even if the fault condition disappears the supply does not restart unless manual or electronic intervention occurs. Manual intervention commonly includes briefly removing and then reconnecting the supply, or it could be done through a switch. Electronic intervention could be done by electronic signals in the Server System.
Monotonically	A waveform changes from one level to another in a steady fashion, without intermediate retracement or oscillation.
Noise	The periodic or random signals over frequency band of 0 Hz to 20 MHz.
Overcurrent	A condition in which a supply attempts to provide more output current than the amount for which it is rated. This commonly occurs if there is a "short circuit" condition in the load attached to the supply.
PFC	Power Factor Corrected.
Ripple	The periodic or random signals over a frequency band of 0 Hz to 20 MHz.
Rise Time	Rise time is defined as the time it takes any output voltage to rise from 10% to 95% of its nominal voltage.
Sag	The condition where the AC line voltage drops below the nominal voltage conditions.
Surge	The condition where the AC line voltage rises above nominal voltage.
VSB or Standby Voltage	An output voltage that is present whenever AC power is applied to the AC inputs of the supply.
MTBF	Mean time between failure.
PWOK	A typical logic level output signal provided by the supply that signals the Server System that all DC output voltages are within their specified range.

4 Mechanical Overview

STATUS
Required

The physical size of the power supply enclosure is intended to accommodate power ranges from 400 to 700 watts. The chassis for the entry power supply is designed using a stretch PS/2 type form factor (see Figure 1). The two rear mounting tabs on the enclosure are **OPTIONAL** and may not be required for many systems.

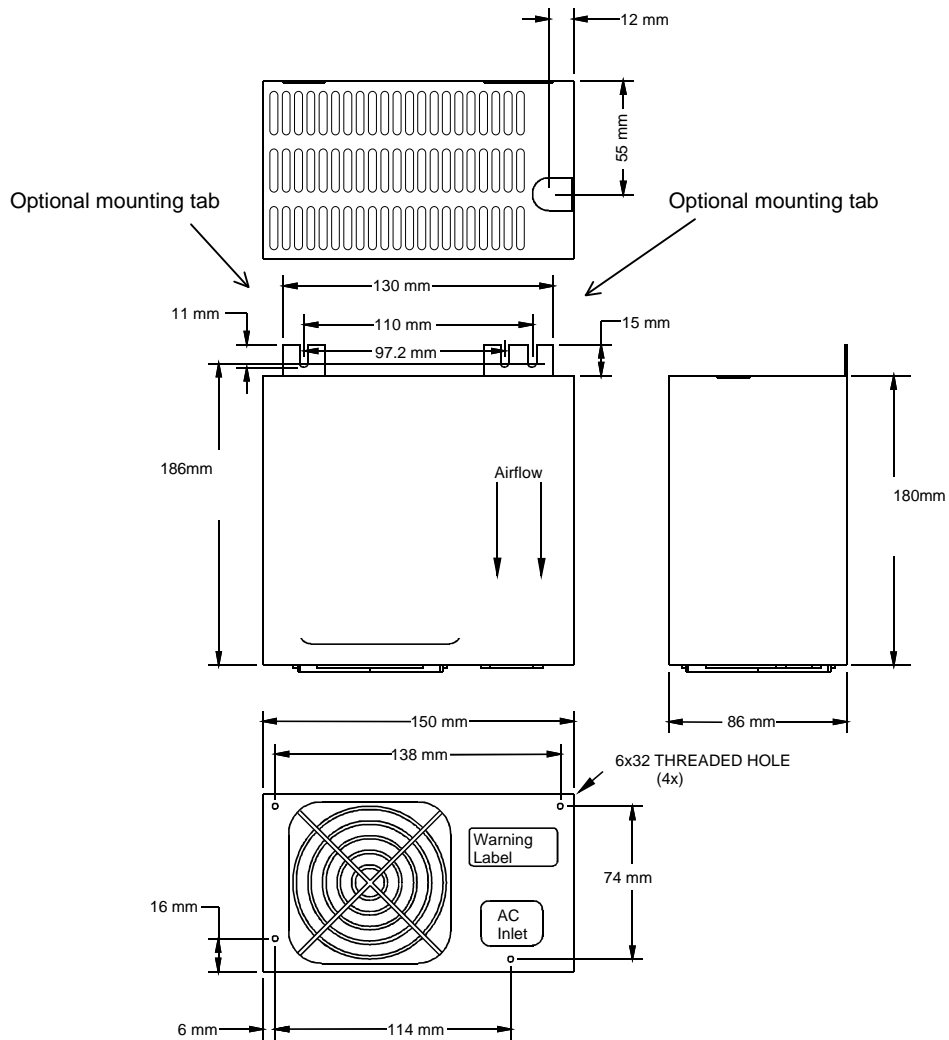

Figure 1: Enclosure Drawing

4.1 Airflow Requirements

STATUS
Recommended

The power supply shall have a two-speed fan(s) and provide cooling to both the supply and the system. During low-speed fan operation, the power supply must not exceed a noise level of 38 dBA measured at one meter on all faces. At low fan speed, the power supply shall provide a minimum of 12 CFM of airflow with 0.003 inH₂O of system backpressure. At high fan speed, the power supply shall provide a minimum of 20 CFM with 0.006 inH₂O of system backpressure.

4.2 Temperature Requirements

STATUS
Recommended

The power supply shall operate within all specified limits over the T_{op} temperature range. The average air temperature difference (ΔT_{ps}) from the inlet to the outlet of the power supply shall not exceed the values shown below in Table 1. All airflow shall pass through the power supply and not over the exterior surfaces of the power supply.

Table 1: Thermal Requirements

ITEM	DESCRIPTION	MIN	MAX	UNITS
T _{op}	Operating temperature range.	0	50	°C
ΔT_{ps}	Temperature rise from inlet air to outlet air of power supply.			
	450 W output power, 20 CFM, Sea level, 25 °C inlet air		20	°C
	550 W output power, 20 CFM, Sea level, 25°C inlet air		25	°C
	450 W output power, 12 CFM, Sea level, 25 °C inlet air		35	°C
	550 W output power, 12 CFM, Sea level, 25 °C inlet air		40	°C
T _{non-op}	Non-operating temperature range.	-40	70	°C

The power supply must meet UL enclosure requirements for temperature rise limits. All sides of the power supply with exception to the air exhaust side, must be classified as “Handle, knobs, grips, etc. held for short periods of time only”.

5 AC Input Requirements

STATUS
Required

The power supply shall incorporate universal power input with active power factor correction, which shall reduce line harmonics in accordance with the EN61000-3-2 and JEIDA MITI standards.

5.1 AC Inlet Connector

STATUS
Required

The AC input connector shall be an *IEC 320 C-14* power inlet. This inlet is rated for 15 A/250 VAC.

5.2 AC Input Voltage Specification

STATUS
Required

The power supply must operate within all specified limits over the following input voltage range. Harmonic distortion of up to 10% THD must not cause the power supply to go out of specified limits. The power supply shall operate properly at 85 VAC input voltage to guarantee proper design margins.

Table 2: AC Input Rating

PARAMETER	MIN	RATED	MAX	Max Input Current (450W)	Max Input Current (550W)	Max Rated Input Current (450W / 550W)
Voltage (110)	90 V _{rms}	100-127 V _{rms}	140 V _{rms}	7.5 A _{rms} ^{1,3}	9.2 A _{rms} ^{1,3}	6.9 A _{rms} / 8.4 A _{rms} ⁴
Voltage (220)	180 V _{rms}	200-240 V _{rms}	264 V _{rms}	3.75 A _{rms} ^{2,3}	4.6 A _{rms} ^{2,3}	3.5 A _{rms} / 4.2 A _{rms} ⁴
Frequency	47 Hz		63 Hz			

- 1 Maximum input current at low input voltage range shall be measured at 90VAC. A 450 W output load shall be applied for the 450 W version and a 550 W output load shall be applied to the 550 W version.
- 2 Maximum input current at high input voltage range shall be measured at 180 VAC. A 450 W output load shall be applied for the 450 W version and a 550 W output load shall be applied to the 550 W version.
- 3 This is not intended to be used for determining agency input current markings.
- 4 Maximum rated input current is measured at 100 VAC and 200 VAC.

5.3 Input Under Voltage

STATUS
Required

The power supply shall contain protection circuitry such that application of an input voltage below the minimum specified in section 5.2 shall not cause damage to the power supply.

5.4 Efficiency

STATUS
Required

The power supply shall have a minimum efficiency of 68% at maximum load and over the specified AC voltage.

5.5 AC Line Dropout

STATUS
Required

An AC line dropout is defined to be when the AC input drops to 0 VAC at any phase of the AC line for any length of time. During an AC dropout of one cycle or less the power supply must meet dynamic voltage regulation requirements over the rated load. An AC line dropout of one cycle or less shall not cause any tripping of control signals or protection circuits. If the AC dropout lasts longer than one cycle, the power supply should recover and meet all turn on requirements. The power supply must meet the AC dropout requirement over rated AC voltages, frequencies, and output loading conditions. Any dropout of the AC line shall not cause damage to the power supply.

5.6 AC Line Fuse

STATUS
Required

The power supply shall incorporate one input fuse on the LINE side for input over-current protection to prevent damage to the power supply and meet product safety requirements. Fuses should be slow blow type or equivalent to prevent nuisance trips. AC inrush current shall not cause the AC line fuse to blow under any conditions. All protection circuits in the power supply shall not cause the AC fuse to blow unless a component in the power supply has failed. This includes DC output load short conditions.

5.7 AC Inrush

STATUS
Required

The power supply must meet inrush requirements for any rated AC voltage, during turn on at any phase of AC voltage, during a single cycle AC dropout condition, during repetitive ON/OFF cycling of AC, and over the specified temperature range (T_{op}). The peak inrush current shall be less than the ratings of its critical components (including input fuse, bulk rectifiers, and surge limiting device).

STATUS
Recommended

An additional inrush current limit is recommended for some system applications that require multiple systems on a single AC circuit. AC line inrush current shall not exceed 50 A peak for one-quarter of the AC cycle, after which, the input current should be no more than the specified maximum input current from Table 2.

5.8 AC Line Transient Specification

STATUS
Recommended

AC line transient conditions shall be defined as “sag” and “surge” conditions. Sag conditions (also referred to as “brownout” conditions) will be defined as the AC line voltage dropping below nominal voltage. Surge will be defined as the AC line voltage rising above nominal voltage.

The power supply shall meet the requirements under the following AC line sag and surge conditions.

Table 3: AC Line Sag Transient Performance

AC Line Sag				
Duration	Sag	Operating AC Voltage	Line Frequency	Performance Criteria
Continuous	10%	Nominal AC Voltage ranges	50/60 Hz	No loss of function or performance
0 to 1 AC cycle	100%	Nominal AC Voltage ranges	50/60 Hz	No loss of function or performance
>1 AC cycle	>10%	Nominal AC Voltage ranges	50/60 Hz	Loss of function acceptable, self recoverable

Table 4: AC Line Surge Transient Performance

AC Line Surge				
Duration	Surge	Operating AC Voltage	Line Frequency	Performance Criteria
Continuous	10%	Nominal AC Voltages	50/60 Hz	No loss of function or performance
0 to ½ AC cycle	30%	Mid-point of nominal AC Voltages	50/60 Hz	No loss of function or performance

5.9 AC Line Fast Transient Specification

STATUS
Recommended

The power supply shall meet the *EN61000-4-5* directive and any additional requirements in *IEC1000-4-5:1995* and the Level 3 requirements for surge-withstand capability, with the following conditions and exceptions:

- These input transients must not cause any out-of-regulation conditions, such as overshoot and undershoot, nor must it cause any nuisance trips of any of the power supply protection circuits.
- The surge-withstand test must not produce damage to the power supply.
- The supply must meet surge-withstand test conditions under maximum and minimum DC-output load conditions.

6 DC Output Specification

6.1 Output Connectors

The power supply shall have the following output connectors and wire harness configuration.

6.1.1 Required Baseboard power connector

STATUS
Required

Connector housing: 24-Pin Molex 39-01-2240 or equivalent

Contact: Molex 44476-1111 or equivalent

Table 5: P1 Baseboard Power Connector

Pin	Signal	18 AWG Color	Pin	Signal	18 AWG Color
1	+3.3 VDC	Orange	13	+3.3 VDC	Orange
2	+3.3 VDC	Orange	14	-12 VDC	Blue
3	COM	Black	15	COM	Black
4	+5 VDC	Red	16	PS_ON	Green
5	COM	Black	17	COM	Black
6	+5 VDC	Red	18	COM	Black
7	COM	Black	19	COM	Black
8	PWR OK	Gray	20	Reserved (-5 V in ATX)	N.C.
9	5 VSB	Purple	21	+5 VDC	Red
10	+12 V2	Yellow	22	+5 VDC	Red
11	+12 V2	Yellow	23	+5 VDC	Red
12	+3.3 VDC	Orange	24	COM	Black

If 240VA limiting is not a requirement for the power supply than all +12V outputs are common and may have the same wire color (yellow).

6.1.2 Required Processor Power Connector

STATUS
Required

Connector housing: 8-Pin Molex 39-01-2080 or equivalent

Contact: Molex 44476-1111 or equivalent

Table 6: Processor Power Connector

Pin	Signal	18 AWG color	Pin	Signal	18 AWG Color
1	COM	Black	5	+12 V1	Yellow/Black Stripe
2	COM	Black	6	+12 V1	Yellow/Black Stripe
3	COM	Black	7	+12 V1	Yellow/Black Stripe
4	COM	Black	8	+12 V1	Yellow/Black Stripe

If 240VA limiting is not a requirement for the power supply than all +12V outputs are common and may have the same wire color (yellow).

6.1.3 Required Peripheral Power Connectors

STATUS
Required

Connector housing: Amp 1-480424-0 or equivalent

Contact: Amp 61314-1 contact or equivalent

Table 7: Peripheral Power Connectors

Pin	Signal	18 AWG Color
1	+12V2 (+12V3)	Yellow (Yellow/Blue Stripe)
2	COM	Black
3	COM	Black
4	+5 VDC	Red

1. For power supply that meet the 240VA power limit levels, the 550W power level has an additional +12V output (+12V3) that is used on the peripheral power connectors. The information in () is for the 550W power supply.
2. If 240VA limiting is not a requirement for the power supply than all +12V outputs are common and may have the same wire color.

6.1.4 Floppy Power Connector

STATUS
Required

Connector housing: Amp 171822-4 or equivalent

Table 8: P8 Floppy Power Connector

Pin	Signal	22 AWG Color
1	+5 VDC	Red
2	COM	Black
3	COM	Black
4	+12 V2 (+12V3) ¹	Yellow (Yellow/Blue Stripe) ¹

1. For power supply that meet the 240VA power limit level, the 550W power level has an additional +12V output (+12V3) that is used on the floppy power connector. The information in () is for the 550W power supply.
2. If 240VA limiting is not a requirement for the power supply than all +12V outputs are common and may have the same wire color.

6.1.5 Optional Server Signal Connector

STATUS
Optional

For server systems with SMBus features, the power supply may have an additional connector, which provides serial SMBus for FRU data and remote sense on 3.3V and Return. If the Server Signal connector is not present, the 3.3V remote sense will be double crimped into one of the 3.3V power contacts in the Baseboard power connector.

Connector housing: 5-pin Molex 50-57-9405 or equivalent

Contacts: Molex 16-02-0088 or equivalent

Table 9: Server Signal Connector

Pin	Signal	24 AWG Color
1	SMBus Clock	White/Green Stripe
2	SMBus Data	White/Yellow Stripe
3	Reserved	NA
4	ReturnS	Black/White Stripe
5	3.3RS	Orange/White Stripe

6.1.6 Optional Workstation Power Connector

STATUS
Optional

For workstation systems with high-powered graphics cards an additional power connector to the baseboard may be needed. This connector supplies additional +3.3V and +12V power for the higher power level graphics cards used in workstation applications.

Connector housing: 6-pin Molex 39-01-2060 or equivalent

Contacts: Molex 44476-1111 or equivalent

Table 10: Workstation Power Connector

Pin	Signal	18 AWG color	Pin	Signal	18 AWG Color
1	+3.3 VDC	Orange	4	COM	Black
2	+3.3 VDC	Orange	5	COM	Black
3	+12 V2	Yellow	6	+12 V2	Yellow

6.2 Grounding

STATUS
Required

The ground of the pins of the power supply wire harness provides the power return path. The wire harness ground pins shall be connected to safety ground (power supply enclosure).

6.3 Remote Sense

STATUS
Optional

The power supply may have remote sense for the +3.3V (3.3VS) and return (ReturnS) if the Optional Server Signal connector is implemented. The remote sense return (ReturnS) is used to regulate out ground drops for all output voltages; +3.3V, +5 V, +12V1, +12V2, +12V3, -12 V, and 5 VSB. The 3.3V remote sense (3.3VS) is used to regulate out drops in the system for the +3.3 V output. The remote sense input impedance to the power supply must be greater than 200 W on 3.3 VS and ReturnS. This is the value of the resistor connecting the remote sense to the output voltage internal to the power supply. Remote sense must be able to regulate out a minimum of 200 mV drop on the +3.3 V output. The remote sense return (ReturnS) must be able to regulate out a minimum of 200 mV drop in the power ground return. The current in any remote sense line shall be less than 5 mA to prevent voltage sensing errors. The power supply must operate within specification over the full range of voltage drops from the power supply's output connector to the remote sense points.

6.4 Output Power/Currents

STATUS
Recommended

The following tables define two power and current ratings for a 450 W and a 550 W power supply. These were selected to cover different types of systems and configurations. The combined output power of all outputs shall not exceed the rated output power. Below are load ranges for each of the two power supply power levels. The power supply must meet both static and dynamic voltage regulation requirements for the minimum loading conditions.

Table 11: 550 W Load Ratings

Load Range 1			
Voltage	Minimum Continuous	Maximum Continuous	Peak
+3.3 V	0.5 A	24 A (36 A) ⁷	
+5 V	5.0 A	24 A	
+12V1	2.0 A	18 A	
+12V2	2.0 A	12 A (18 A) ⁷	
+12V3	3.0 A	8.0 A	13 A
-12 V	0 A	0.5 A	
+5 VSB	0.1 A	2.0 A	

Load Range 2			
Voltage	Minimum Continuous	Maximum Continuous	Peak
+3.3 V	0.5 A	9 A	
+5 V	2.0 A	7 A	
+12V1	1.0 A	9 A	
+12V2	0.5 A	6 A	9.0 A
+12V3	2.0 A	5 A	
-12 V	0 A	0.5 A	
+5 VSB	0.1 A	2.0 A	

1. Maximum continuous total DC output power should not exceed 550 W.
2. Maximum continuous combined load on +3.3 VDC and +5 VDC outputs shall not exceed 140 W.
3. Maximum peak total DC output power should not exceed 610 W.
4. Peak power and current loading shall be supported for a minimum of 1 second.
5. Maximum combined current for the 12 V outputs shall be 35 A.
6. Peak current for the combined 12 V outputs shall be 40 A.
7. The additional +3.3V and +12V2 current requirements shown in () are for workstation applications that require the high power graphics card power connector.

Table 12: 450 W Load Ratings

Load Range 1			
Voltage	Minimum Continuous	Maximum Continuous	Peak
+3.3 V	0.5 A	24 A	
+5 V	5.0 A	20 A	
+12V1	2.0 A	15 A	18 A
+12V2	2.0 A	15 A	18 A
-12 V	0 A	0.5 A	
+5 VSB	0.1 A	2.0 A	

Load Range 2			
Voltage	Minimum Continuous	Maximum Continuous	Peak
+3.3 V	0.5 A	9 A	
+5 V	2.0 A	7 A	
+12V1	0.5 A	7 A	9 A
+12V2	1.0 A	9 A	14 A
-12 V	0 A	0.5 A	
+5 VSB	0.1 A	2.0 A	

- 1 Maximum continuous total DC output power should not exceed 450 W.
- 2 Maximum continuous combined load on +3.3 VDC and +5 VDC outputs shall not exceed 120 W.
- 3 Maximum Peak total DC output power should not exceed 520 W.
- 4 Peak power and current loading shall be supported for a minimum of 1 second.
- 5 Maximum combined current for the 12 V outputs shall be 30 A.
- 6 Maximum 12V combined peak current shall be 36A.

6.4.1 Standby Outputs

STATUS
Required

The 5 VSB output shall be present when an AC input greater than the power supply turn on voltage is applied.

6.5 Voltage Regulation

STATUS
Required

The power supply output voltages must stay within the following voltage limits when operating at steady state and dynamic loading conditions. These limits include the peak-peak ripple/noise specified in Section 6.8. All outputs are measured with reference to the return remote sense (ReturnS) signal. The 5 V, 12V1, 12V2, 12V3, -12 V and 5 VSB outputs are measured at the power supply connectors referenced to ReturnS. The +3.3 V is measured at its remote sense signal (3.3VS) located at the signal connector.

Table 13: Voltage Regulation Limits

Parameter	MIN	NOM	MAX	Units	Tolerance
+3.3 V	+3.20	+3.30	+3.46	V _{rms}	+5/-3%
+5 V	+4.80	+5.00	+5.25	V _{rms}	+5/-4%
+12V1	+11.52	+12.00	+12.60	V _{rms}	+5/-4%
+12V2	+11.52	+12.00	+12.60	V _{rms}	+5/-4%
+12V3	+11.52	+12.00	+12.60	V _{rms}	+5/-4%
-12 V	-11.40	-12.20	-13.08	V _{rms}	+9/-5%
+5 VSB	+4.85	+5.00	+5.25	V _{rms}	+5/-4%

STATUS
Optional

Some system applications may require tighter regulation limits on the +5 V output. The optional regulation limits are shown below.

Table 14: Optional +5V Regulation Limits

Parameter	MIN	NOM	MAX	Units	Tolerance
+5 V	+5.85	+5.00	+5.25	V _{rms}	+5/-3%

6.6 Dynamic Loading

STATUS
Required

The output voltages shall remain within the limits specified in Table 13 for the step loading and within the limits specified in Table 15 for the capacitive loading specified in below. The load transient repetition rate shall be tested between 50 Hz and 5 kHz at duty cycles ranging from 10%-90%. The load transient repetition rate is only a test specification. The Δ step load may occur anywhere within the MIN load to the MAX load shown in Table 11 and Table 12.

Table 15: Transient Load Requirements

Output	D Step Load Size	Load Slew Rate	Capacitive Load
+3.3 V	30% of max load	0.5 A/ μ s	1,000 μ F
+5 V	30% of max load	0.5 A/ μ s	1,000 μ F
12V1+12V2+12V3	65% of max load	0.5 A/ μ s	1,000 μ F
+5 VSB	25% of max load	0.5 A/ μ s	1 μ F

6.7 Capacitive Loading

STATUS
Required

The power supply shall be stable and meet all requirements with the following capacitive loading ranges.

Table 16: Capacitive Loading Conditions

Output	MIN	MAX	Units
+3.3 V	10	12,000	μF
+5 V	10	12,000	μF
+12 V	10	11,000	μF
-12 V	1	350	μF
+5 VSB	1	350	μF

6.8 Ripple / Noise

STATUS
Required

The maximum allowed ripple/noise output of the power supply is defined in Table 17. This is measured over a bandwidth of 0 Hz to 20 MHz at the power supply output connectors. A 10 μF tantalum capacitor in parallel with a 0.1 μF ceramic capacitor are placed at the point of measurement.

Table 17: Ripple and Noise

+3.3 V	+5 V	+12 V	-12 V	+5 VSB
50 mVp-p	50 mVp-p	120 mVp-p	120 mVp-p	50 mVp-p

6.9 Timing Requirements

STATUS
Required

These are the timing requirements for the power supply operation. The output voltages must rise from 10% to within regulation limits (T_{vout_rise}) within 5 to 70 ms. The +3.3 V, +5 V and +12 V output voltages should start to rise at about the same time. All outputs must rise monotonically. The +5 V output needs to be greater than the +3.3 V output during any point of the voltage rise. The +5V output must never be greater than the +3.3V output by more than 2.25 V. Each output voltage shall reach regulation within 50 ms (T_{vout_on}) of each other during turn on of the power supply. Each output voltage shall fall out of regulation within 400 ms (T_{vout_off}) of each other during turn off. Figure 2 and Figure 3 show the turn ON and turn OFF timing requirements. In Figure 3 the timing is shown with both AC and PSON# controlling the ON/OFF of the power supply.

Table 18: Output Voltage Timing

Item	Description	MIN	MAX	Units
T_{vout_rise}	Output voltage rise time from each main output.	5	70	ms
T_{vout_on}	All main outputs must be within regulation of each other within this time.		50	ms
T_{vout_off}	All main outputs must leave regulation within this time.		400	ms

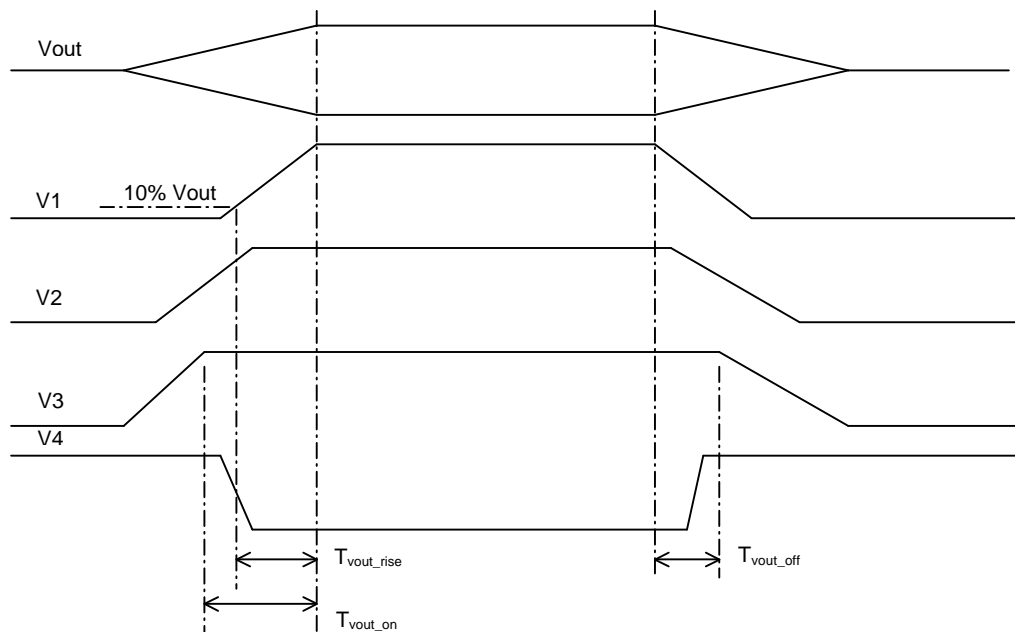

Figure 2: Output Voltage Timing

Table 19: Turn On/Off Timing

Item	Description	MIN	MAX	UNITS
T _{sb_on_delay}	Delay from AC being applied to 5 VSB being within regulation.		1500	ms
T _{ac_on_delay}	Delay from AC being applied to all output voltages being within regulation.		2500	ms
T _{vout_holdup}	Time all output voltages stay within regulation after loss of AC.	18		ms
T _{pwok_holdup}	Delay from loss of AC to deassertion of PWOK.	17		ms
T _{pson_on_delay}	Delay from PSON# active to output voltages within regulation limits.	5	400	ms
T _{pson_pwok}	Delay from PSON# deactive to PWOK being deasserted.		50	ms
T _{pwok_on}	Delay from output voltages within regulation limits to PWOK asserted at turn on.	200	1000	ms
T _{pwok_off}	Delay from PWOK deasserted to output voltages (3.3 V, 5 V, 12 V, -12 V) dropping out of regulation limits.	1		ms
T _{pwok_low}	Duration of PWOK being in the deasserted state during an off/on cycle using AC or the PSON# signal.	100		Ms
T _{sb_vout}	Delay from 5 VSB being in regulation to O/Ps being in regulation at AC turn on.	50	1000	Ms

STATUS
Recommended

Item	Description	MIN	MAX	UNITS
T _{vout_holdup}	Time all output voltages stay within regulation after loss of AC.	21		ms
T _{pwok_holdup}	Delay from loss of AC to deassertion of PWOK.	20		ms
T _{sb_holdup}	Time 5VSB output voltage stays within regulation after loss of AC.	70		ms

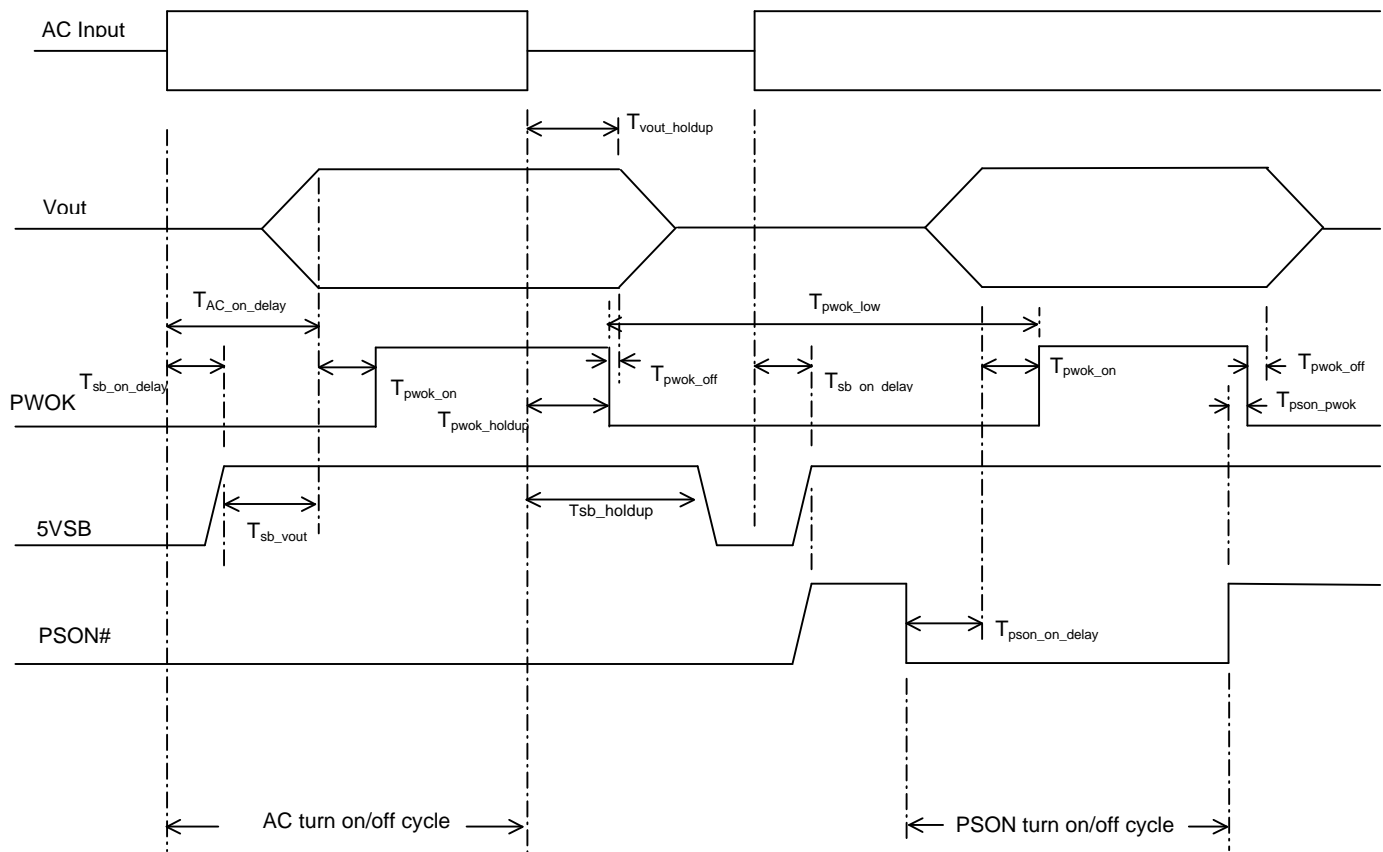

Figure 3: Turn On/Off Timing (Single Power Supply)

7 Protection Circuits

STATUS
Required

Protection circuits inside the power supply shall cause only the power supply's main outputs to shutdown. If the power supply latches off due to a protection circuit tripping, an AC cycle OFF for 15 s and a PSON[#] cycle HIGH for 1 s must be able to reset the power supply.

7.1 Current Limit

STATUS
Required

The power supply shall have current limit to prevent the +3.3 V, +5 V, and +12 V outputs from exceeding the values shown in Table 20. If the current limits are exceeded the power supply shall shutdown and latch off. The latch will be cleared by toggling the PSON[#] signal or by an AC power interruption. The power supply shall not be damaged from repeated power cycling in this condition. -12 V and 5 VSB shall be protected under over current or shorted conditions so that no damage can occur to the power supply. All outputs shall be protected so that no damage occurs to the power supply under a shorted output condition.

Table 20: Over Current Protection

Voltage	Over Current Limit (I _{out} limit)
+3.3 V	110% minimum; 150% maximum
+5 V	110% minimum; 150% maximum
+12V	110% minimum; 150% maximum

7.2 240VA Protection

STATUS
Recommended

System designs may require user access to energized areas of the system. In these cases the power supply may be required to meet regulatory 240VA limits for any power rail. Since the +12V rail combined power exceeds 240VA it must be divided into separate channels to meet this requirement. Each separate rail needs to be limited to less than 20A for each +12V rail. The separate +12V rails do not necessarily need to be independently regulated outputs. They can share a common power conversion stage. The +12V rail is divided into two rails for the 450W power level and three rails for the 550W power level. +12V1 is dedicated for providing power to the input of the processor voltage regulator(s). The +12V2 rail is used to power the rest of the main board +12V power needs and peripherals devices. The +12V3 on the 550W power supply is used to power peripheral devices only.

Table 21: Over Current Protection

Voltage	Over Current Limit (Iout limit)
+3.3 V	110% minimum; 150% maximum
+5 V	110% minimum; 150% maximum
+12V1	18A minimum; 20A maximum
+12V2	18A minimum; 20A maximum
+12V3 (550W only)	15A minimum; 20A maximum

7.3 Over Voltage Protection

STATUS
Required

The power supply over voltage protection shall be locally sensed. The power supply shall shutdown and latch off after an over voltage condition occurs. This latch shall be cleared by toggling the PSON[#] signal or by an AC power interruption. Table 22 contains the over voltage limits. The values are measured at the output of the power supply's connectors. The voltage shall never exceed the maximum levels when measured at the power pins of the power supply connector during any single point of fail. The voltage shall never trip any lower than the minimum levels when measured at the power pins of the power supply connector.

Table 22: Over Voltage Limits

Output Voltage	MIN (V)	MAX (V)
+3.3 V	3.9	4.5
+5 V	5.7	6.5
+12V1,2,3	13.3	14.5
-12 V	-13.3	-14.5
+5 VSB	5.7	6.5

7.4 Over Temperature Protection

STATUS
Recommended

The power supply will be protected against over temperature conditions caused by loss of fan cooling or excessive ambient temperature. In an OTP condition the PSU will shutdown. When the power supply temperature drops to within specified limits, the power supply shall restore power automatically. The OTP circuit must have built in hysteresis such that the power supply will not oscillate on and off due to temperature recovering condition. The OTP trip level shall have a minimum of 4 °C of ambient temperature hysteresis.

8 Control and Indicator Functions

The following sections define the input and output signals from the power supply.

Signals that can be defined as low true use the following convention:

$signal^\# = \text{low true}$

8.1 PSON#

STATUS
Required

The PSON# signal is required to remotely turn on/off the power supply. PSON# is an active low signal that turns on the +3.3 V, +5 V, +12 V, and -12 V power rails. When this signal is not pulled low by the system, or left open, the outputs (except the +5 VSB) turn off. This signal is pulled to a standby voltage by a pull-up resistor internal to the power supply. Refer to Figure 3 for timing diagram.

Table 23: PSON# Signal Characteristic

Signal Type	Accepts an open collector/drain input from the system. Pull-up to VSB located in power supply.	
PSON# = Low	ON	
PSON# = Open or High	OFF	
	MIN	MAX
Logic level low (power supply ON)	0 V	1.0 V
Logic level high (power supply OFF)	2.0 V	5.25 V
Source current, $V_{pson} = \text{low}$		4 mA
Power up delay: $T_{pson_on_delay}$	5 ms	400 ms
PWOK delay: T_{pson_pwok}		50 ms

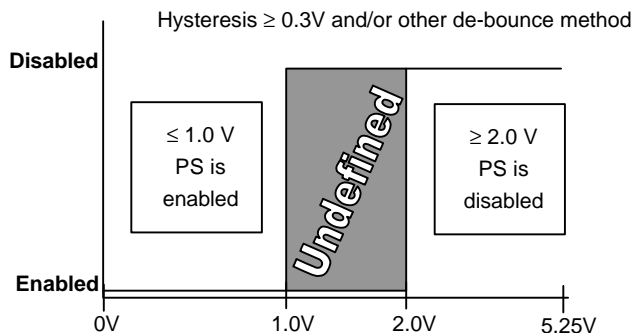

Figure 4: PSON# Signal Characteristics

8.2 PWOK (Power OK)

STATUS
Required

PWOK is a power OK signal and will be pulled HIGH by the power supply to indicate that all the outputs are within the regulation limits of the power supply. When any output voltage falls below regulation limits or when AC power has been removed for a time sufficiently long so that power supply operation is no longer guaranteed, PWOK will be deasserted to a LOW state. See Figure 3 for a representation of the timing characteristics of PWOK. The start of the PWOK delay time shall be inhibited as long as any power supply output is in current limit.

Table 24: PWOK Signal Characteristics

Signal Type	Open collector/drain output from power supply. Pull-up to VSB located in power supply.	
PWOK = High	Power OK	
PWOK = Low	Power Not OK	
	MIN	MAX
Logic level low voltage, Isink = 4 mA	0 V	0.4 V
Logic level high voltage, Isource=200 mA	2.4 V	5.25 V
Sink current, PWOK = low		4 mA
Source current, PWOK = high		2 mA
PWOK delay: T_{pwok_on}	200 ms	1000 ms
PWOK rise and fall time		100 μs
Power down delay: T_{pwok_off}	1 ms	200 ms

8.3 Field Replacement Unit (FRU) Signals

STATUS
Optional

Two pins will be allocated for the FRU information on the power supply connector. One pin is the Serial Clock (SCL). The second pin is used for Serial Data (SDA). Both pins are bi-directional and are used to form a serial bus. The FRU circuits inside the power supply must be powered off of 5 VSB output and grounded to ReturnS (remote sense return). The Write Control (or Write protect) pin should be tied to ReturnS inside the power supply so that information can be written to the EEPROM.

8.3.1 FRU Data

FRU data shall be stored starting in address location 8000h through 80FFh. The FRU data format shall be compliant with the IPMI specifications. The current version of these specifications are available at: <http://developer.intel.com/design/servers/ipmi/spec.htm>.

8.3.2 FRU Data Format

Table 25: FRU Device Information

Area Type	Description
Common Header	As defined by the FRU document
Internal Use Area	Not required, do not reserve
Chassis Info Area	Not applicable, do not reserve
Board Info Area	Not applicable, do not reserve

8.3.2.1 Product Info Area

As defined by the IPMI FRU document. Product information shall be defined as follows:

Table 26: FRU Device Product Information Area

Field Name	Field Description
Manufacturer Name	{Formal name of manufacturer}
Product Name	{Manufacturer's model number}
Product part/model number	Customer part number
Product Version	Customer current revision
Product Serial Number	{Defined at time of manufacture}
Asset Tag	{Not used, code is zero length byte}
FRU File ID	{Not required}
PAD Bytes	{Added as necessary to allow for 8-byte offset to next area}

8.3.2.2 MultiRecord Area

As defined by the IPMI FRU document. The following record types shall be used on this power supply:

- Power Supply Information (Record Type 0x00)
- DC Output (Record Type 0x01)
- No other record types are required for the power supply.

MultiRecord information shall be defined as follows:

Table 27: MultiRecord information Area

Field Name (PS Info)	Field Information Definition
Overall Capacity (watts)	550 {Low power version would be 450}
Peak VA	610 {Low power version would be 490}
Inrush current (A)	50
Inrush interval (ms)	5
Low end input voltage range 1	90
High end input voltage range 1	140
Low end input voltage range 2	180
High end input voltage range 2	264
A/C dropout tol. (ms)	20
Binary flags	Set for: Hot Swap support, Autoswitch, and PFC
Peak Wattage	Set for: 10 s, 610 W {Low power version would be 490 W}
Combined wattage	Set for 5 V & 3.3V combined wattage of 115 W {Low power version would be 115 W}
Predictive fail tach support	Not supported, 00h value
Field Name (Output)	Field Description
Five outputs are to be defined from #1 to #5, as follows: +3.3 V, +5 V, +12 V, -12V, and +5 VSB.	
Output Information	Set for: Standby on +5 VSB, No Standby on all others.
All other output fields	Format per IPMI specification, using parameters in the EPS12V specification.

9 MTBF

STATUS
Recommended

The power supply shall have a minimum MTBF at continuous operation of 1) 50,000 hours at 100% load and 50 °C, as calculated by Bellcore RPP, or 2) 100,000 hours demonstrated at 100% load and 50 °C.

10 Agency Requirements

STATUS
Recommended

The power supply must comply with all regulatory requirements for its intended geographical market. Depending on the chosen market, regulatory requirements may vary. Although a power supply can be designed for worldwide compliance, there may be cost factors that drive different versions of supplies for different geographically targeted markets.

This specification requires that the power supply meet all regulatory requirements for the intended market at the time of manufacturing. Typically this includes:

- UL
- CSA
- A Nordic CENELEC
- TUV
- VDE
- CISPR Class B
- FCC Class B

The power supply, when installed in the system, shall meet immunity requirements specified in EN55024. Specific tests are to be EN61000-4-2 ,-3, -4, -5, -6, -8, -11, EN61000-3-2, -3, and JEIDI MITI standard. The power supply must maintain normal performance within specified limits. This testing must be completed by the system EMI engineer. Conformance must be designated with the European Union CE Marking. Specific immunity level requirements are left to customer requirements.